

# HIGH OUTPUT

	A	B	C	D	E	F	G	H	SERIES 3 L INSTALLATION	
INCH	.562	7.211	1.125	.687	8.250	7.430	6.500	2.180	MAXIMUM RECOMMENDED FASTENER TORQUE	200 INCH LBS.
MM	14.27	183.1	28.57	17.44	209.5	188.7	165.1	55.37		22.59 Nm

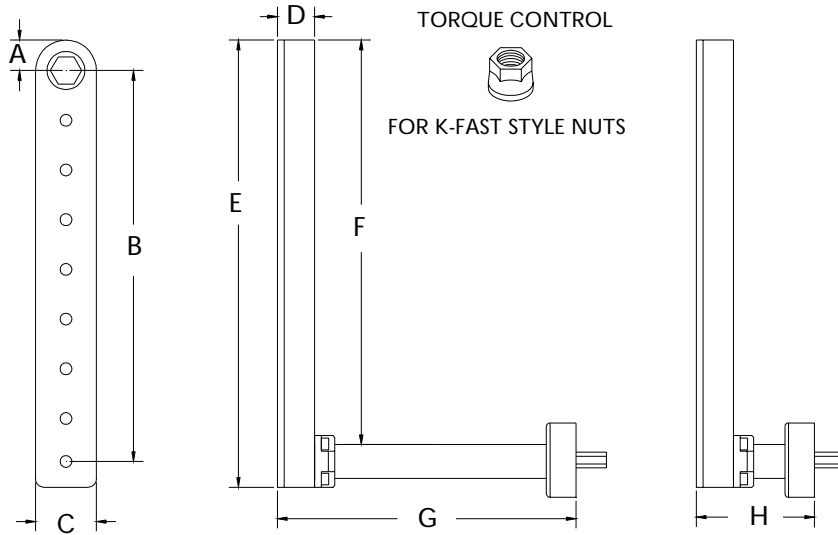

13222 ATTACHMENT ONLY EXTENDED

13223 ATTACHMENT ONLY SHORT

TORQUE CONTROL L TOOLS			TORQUE RANGE		TOOL ORDER NUMBERS	
MOTOR	RPM	REVERSIBLE	TORQUE INCH LB.	TORQUE Nm	WITH EXTENDED	WITH SHORT
.45 HP	200	YES	10 - 122	1.1 - 13.7	13586	13587
.45 HP	400	YES	10 - 108	1.1 - 12.2	13588	13589

TOOL ORDER NUMBER PLUS  
NOSE GEAR NUMBER = COMPLETE TOOL

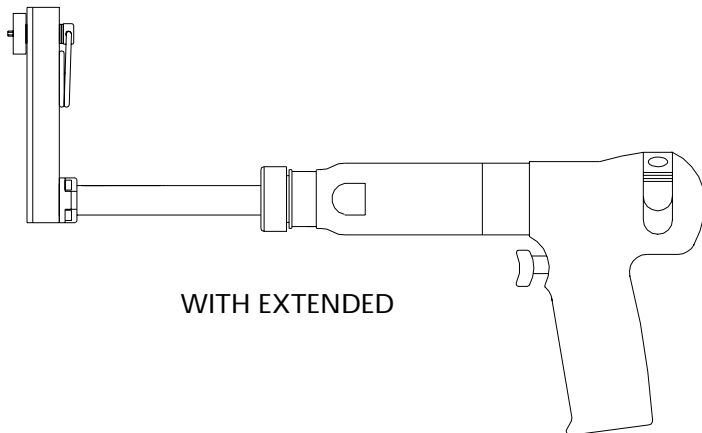

WITH EXTENDED

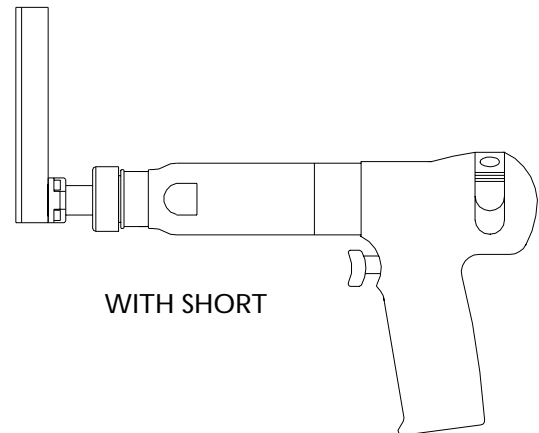

WITH SHORT

NOSE GEARS FOR SOCKETS.  
HEX DRIVER FOR UAT SOCKET SYSTEM.

PART NO.	SIZE	TYPE
12479	3/8	HEX DRIVER
12480	3/8	SQ DRIVE MALE

FLUSH STYLE.  
THE SOCKET HEX IS BUILT INTO  
THE GEAR OF THE TOOL.  
NO SOCKET IS USED

PART NO.	HEX SIZE	TYPE
12481	5/16	HEX FLU SH
12482	11/32	HEX FLU SH
12483	3/8	HEX FLU SH
12484	7/16	HEX FLU SH
12485	1/2	HEX FLU SH

HEX THRU STYLE.  
HEX RUNS THROUGH NOSE GEAR.  
HEX KEY SPRING IS NOT SUPPLIED.

PART NO.	HEX SIZE	TYPE
12486	5/16	HEX THRU
12487	11/32	HEX THRU
12488	3/8	HEX THRU
12489	7/16	HEX THRU
12490	1/2	HEX THRU

FOR TWELVE POINT CONFIGURATION ADD X TO NOSE GEAR PART No.