

HIGH OUTPUT

	A	B	C	D	E	F	G	H	SERIES 2 L INSTALLATION	
INCH	.317	4.812	.750	.500	5.514	4.817	6.425	2.125	MAXIMUM RECOMMENDED FASTENER TORQUE	120 INCH LBS.
MM	8.05	122.2	19.05	12.70	140.0	122.3	163.1	53.97		13.55 Nm

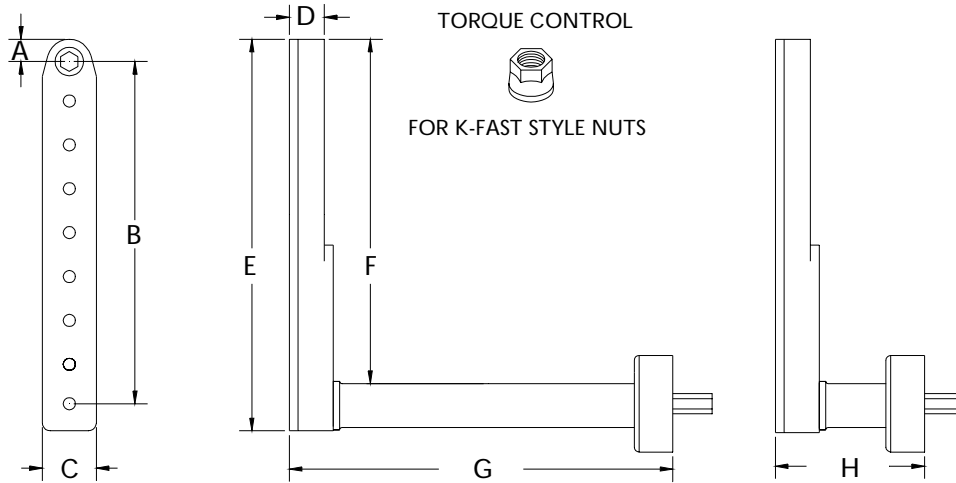

13208 ATTACHMENT ONLY EXTENDED

13209 ATTACHMENT ONLY SHORT

TORQUE CONTROL L TOOLS			TORQUE RANGE		TOOL ORDER NUMBERS	
MOTOR	RPM	REVERSIBLE	TORQUE INCH LB.	TORQUE Nm	WITH EXTENDED	WITH SHORT
.33 HP	175	YES	4 - 54	.4 - 6.1	13466	13467
.33 HP	420	YES	4 - 36	.4 - 4.0	13468	13469
.45 HP	200	YES	5 - 65	.5 - 7.3	13470	13471
.45 HP	400	YES	5 - 57	.5 - 6.4	13472	13473

TOOL ORDER NUMBER PLUS
NOSE GEAR NUMBER = COMPLETE TOOL

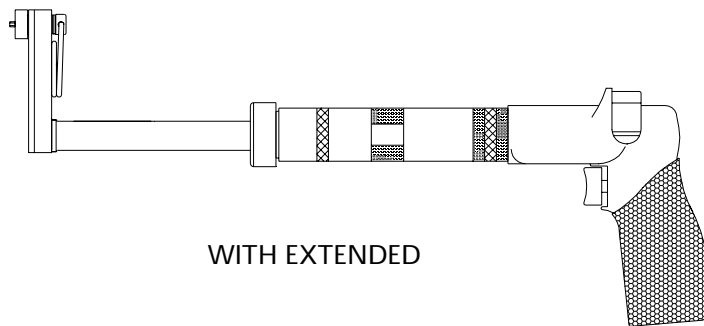

WITH EXTENDED

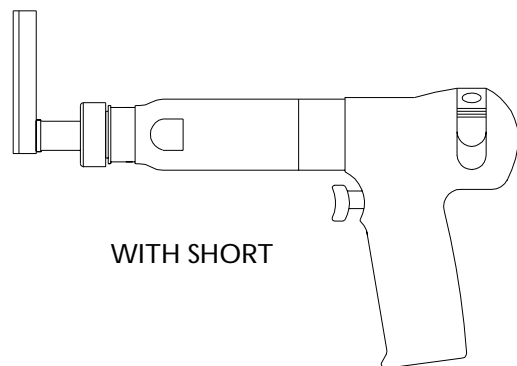

WITH SHORT

NOSE GEARS FOR SOCKETS.
HEX DRIVER FOR HO SERIES 2 SOCKETS

PART NO.	SIZE	TYPE
12467	9/32	HEX DRIVER
12468	1/4	SQ DRIVE MALE

FLUSH STYLE.
THE SOCKET HEX IS BUILT INTO
THE GEAR OF THE TOOL.
NO SOCKET IS USED

PART NO.	HEX SIZE	TYPE
12469	7/32	HEX FLUSH
12470	1/4	HEX FLUSH
12471	9/32	HEX FLUSH

HEX THRU STYLE.
HEX RUNS THROUGH NOSE GEAR.
HEX KEY SPRING IS NOT SUPPLIED.

PART NO.	HEX SIZE	TYPE
12474	3/16	HEX THRU
12475	7/32	HEX THRU
12476	1/4	HEX THRU
12477	9/32	HEX THRU

FOR TWELVE POINT CONFIGURATION ADD X TO NOSE GEAR PART No.