

HIGH OUTPUT

	A	B	C	D	E	F	G	H	SERIES 2 L INSTALLATION	
INCH	.317	4.250	.750	.500	4.327	4.255	6.425	2.125	MAXIMUM RECOMMENDED FASTENER TORQUE	120 INCH LBS.
MM	8.05	107.9	19.05	12.70	109.9	108.0	163.1	53.97		13.55 Nm

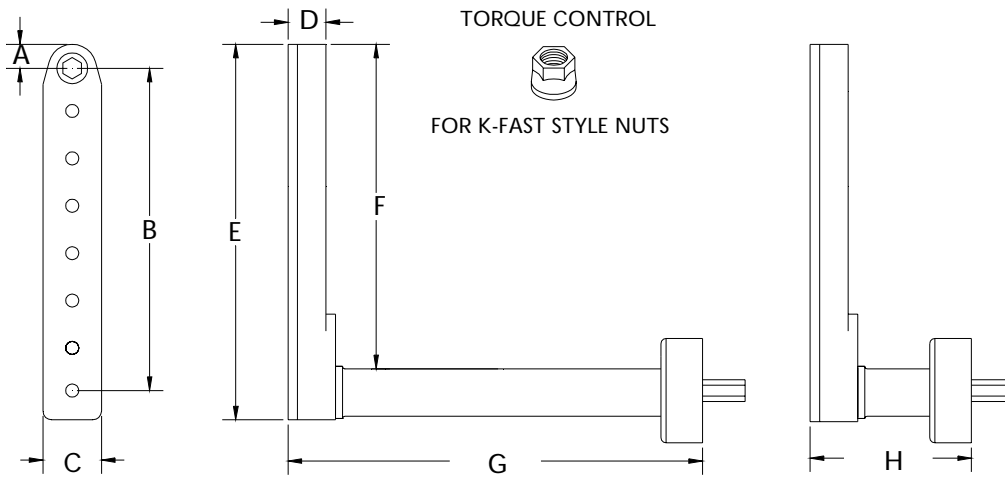

15045 ATTACHMENT ONLY EXTENDED

15046 ATTACHMENT ONLY SHORT

8 GEAR ATTACHMENTS REQUIRE REVERSE RUNNING (K) OR REVERSIBLE MOTORS

TORQUE CONTROL L TOOLS			OUTPUT AT FASTENER		TOOL ORDER NUMBERS	
MOTOR	RPM	REVERSIBLE	TORQUE INCH LB.	TORQUE Nm	WITH EXTENDED	WITH SHORT
.33 HP	175	YES	4 - 66	.4 - 7.4	15923	15924
.33 HP	420	YES	4 - 44	.4 - 4.9	15925	15926
.45 HP	200	YES	5 - 79	.5 - 8.9	15927	15928
.45 HP	400	YES	5 - 70	.5 - 7.9	15929	15930

TOOL ORDER NUMBER PLUS
NOSE GEAR NUMBER = COMPLETE TOOL

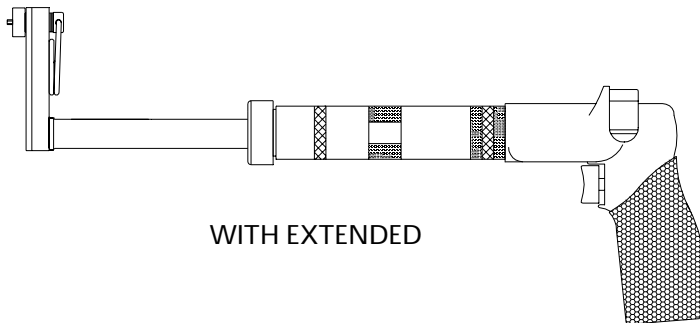

WITH EXTENDED

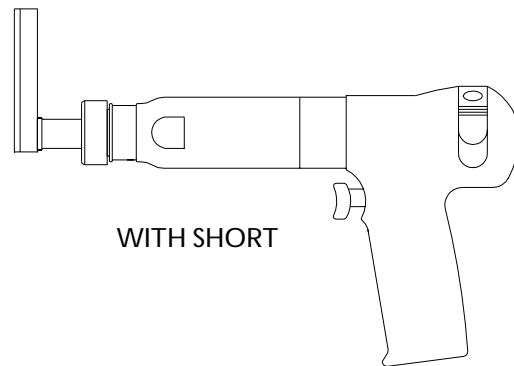

WITH SHORT

NOSE GEARS FOR SOCKETS.
HEX DRIVER FOR HO SERIES 2 SOCKETS

PART NO.	SIZE	TYPE
12467	9/32	HEX DRIVER
12468	1/4	SQ DRIVE MALE

FLUSH STYLE.
THE SOCKET HEX IS BUILT INTO
THE GEAR OF THE TOOL.
NO SOCKET IS USED

PART NO.	HEX SIZE	TYPE
12469	7/32	HEX FLUSH
12470	1/4	HEX FLUSH
12471	9/32	HEX FLUSH

HEX THRU STYLE.
HEX RUNS THROUGH NOSE GEAR.
HEX KEY SPRING IS NOT SUPPLIED.

PART NO.	HEX SIZE	TYPE
12474	3/16	HEX THRU
12475	7/32	HEX THRU
12476	1/4	HEX THRU
12477	9/32	HEX THRU

FOR TWELVE POINT CONFIGURATION ADD X TO NOSE GEAR PART No.