

# HIGH OUTPUT

	A	B	C	D	E	F	G	H	SERIES 2 L INSTALLATION	
INCH	.317	1.187	.750	.500	2.437	3.282	6.425	2.125	MAXIMUM RECOMMENDED FASTENER TORQUE	120 INCH LBS.
MM	8.05	30.14	19.05	12.70	61.89	83.36	163.1	53.97		13.55 Nm

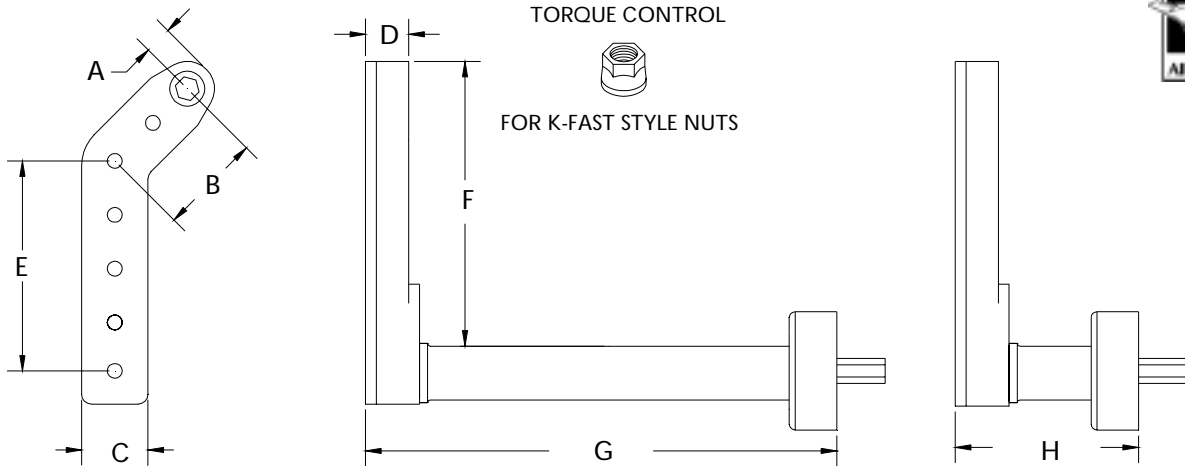

13212 ATTACHMENT ONLY EXTENDED

13213 ATTACHMENT ONLY SHORT

TORQUE CONTROL L TOOLS			TORQUE RANGE		TOOL ORDER NUMBERS	
MOTOR	RPM	REVERSIBLE	TORQUE INCH LB.	TORQUE Nm	WITH EXTENDED	WITH SHORT
.33 HP	175	YES	5 - 78	.5 - 8.8	13510	13511
.33 HP	420	YES	5 - 52	.5 - 5.8	13512	13513
.45 HP	200	YES	8 - 93	.9 - 10.5	13514	13515
.45 HP	400	YES	8 - 83	.9 - 9.3	13516	13517

TOOL ORDER NUMBER PLUS NOSE GEAR NUMBER = COMPLETE TOOL

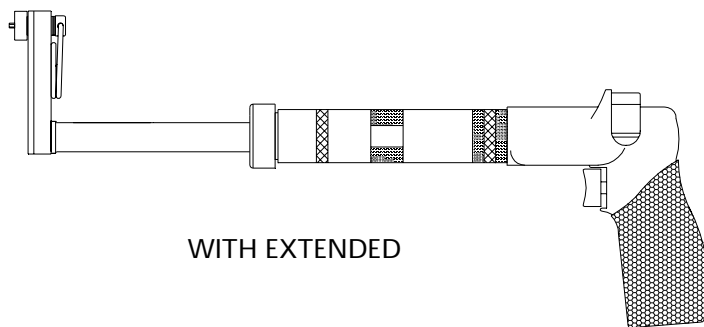

WITH EXTENDED

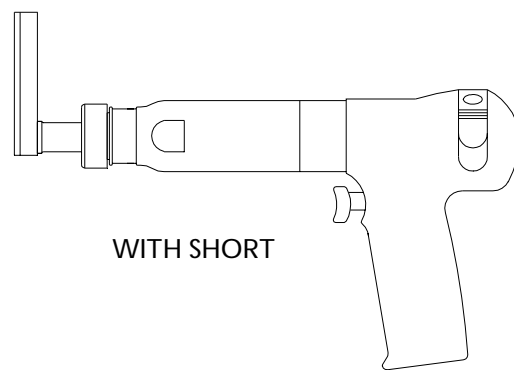

WITH SHORT

NOSE GEARS FOR SOCKETS.  
HEX DRIVER FOR HO SERIES 2 SOCKETS

PART NO.	SIZE	TYPE
12467	9/32	HEX DRIVER
12468	1/4	SQ DRIVE MALE

FLUSH STYLE.  
THE SOCKET HEX IS BUILT INTO THE GEAR OF THE TOOL.  
NO SOCKET IS USED

PART NO.	HEX SIZE	TYPE
12469	7/32	HEX FLUSH
12470	1/4	HEX FLUSH
12471	9/32	HEX FLUSH

HEX THRU STYLE.  
HEX RUNS THROUGH NOSE GEAR.  
HEX KEY SPRING IS NOT SUPPLIED.

PART NO.	HEX SIZE	TYPE
12474	3/16	HEX THRU
12475	7/32	HEX THRU
12476	1/4	HEX THRU
12477	9/32	HEX THRU

FOR TWELVE POINT CONFIGURATION ADD X TO NOSE GEAR PART No.