

# HIGH OUTPUT

	A	B	C	D	E	F	G	H	SERIES 2 L INSTALLATION	
INCH	.317	3.625	.750	.500	4.327	3.630	6.425	2.125	MAXIMUM RECOMMENDED FASTENER TORQUE	120 INCH LBS.
MM	8.05	92.07	19.05	12.70	109.9	92.20	163.1	53.97		13.55 Nm

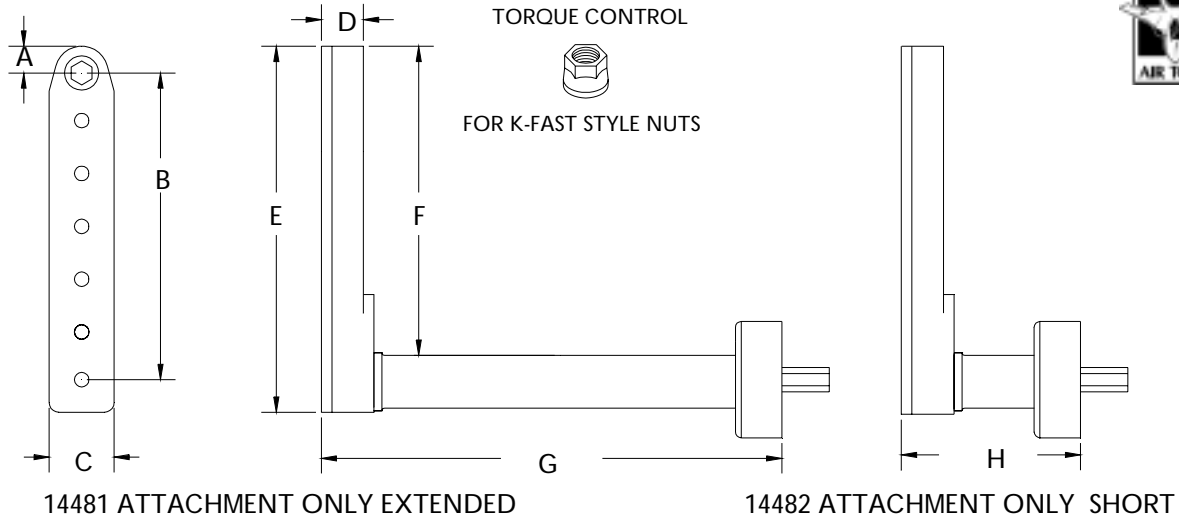

TORQUE CONTROL L TOOLS			OUTPUT AT FASTENER		TOOL ORDER NUMBERS	
MOTOR	RPM	REVERSIBLE	TORQUE INCH LB.	TORQUE Nm	WITH EXTENDED	WITH SHORT
.33 HP	175	YES	5 - 78	.5 - 8.8	13444	13445
.33 HP	420	YES	5 - 52	.5 - 5.8	13446	13447
.45 HP	200	YES	8 - 93	.9 - 10.5	13448	13449
.45 HP	400	YES	8 - 83	.9 - 9.3	13450	13451

TOOL ORDER NUMBER PLUS  
NOSE GEAR NUMBER = COMPLETE TOOL

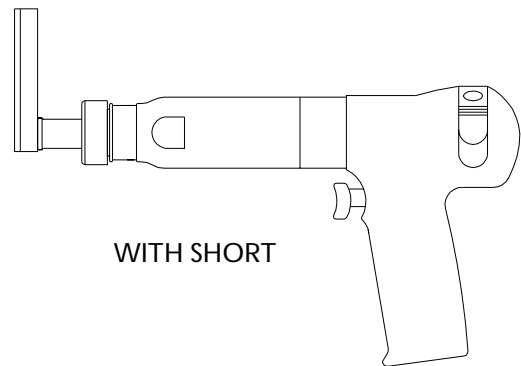
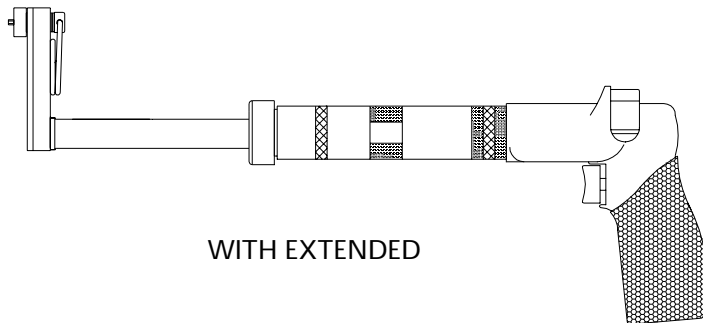

NOSE GEARS FOR SOCKETS.  
HEX DRIVER FOR HO SERIES 2 SOCKETS

PART NO.	SIZE	TYPE
12467	9/32	HEX DRIVER
12468	1/4	SQ DRIVE MALE

FLUSH STYLE.  
THE SOCKET HEX IS BUILT INTO  
THE GEAR OF THE TOOL.  
NO SOCKET IS USED

PART NO.	HEX SIZE	TYPE
12469	7/32	HEX FLUSH
12470	1/4	HEX FLUSH
12471	9/32	HEX FLUSH

HEX THRU STYLE.  
HEX RUNS THROUGH NOSE GEAR.  
HEX KEY SPRING IS NOT SUPPLIED.

PART NO.	HEX SIZE	TYPE
12474	3/16	HEX THRU
12475	7/32	HEX THRU
12476	1/4	HEX THRU
12477	9/32	HEX THRU

FOR TWELVE POINT CONFIGURATION ADD X TO NOSE GEAR PART No.