

	A	B	C	D	E	F	G	H	SERIES 2 HW L INSTALLATION	
INCH	.500	2.314	1.062	.500	3.290	2.500	6.300	2.000	MAXIMUM RECOMMENDED FASTENER TORQUE	160 INCH LBS.
MM	12.7	58.77	26.97	12.70	83.56	63.50	160.0	50.80		18.07 Nm

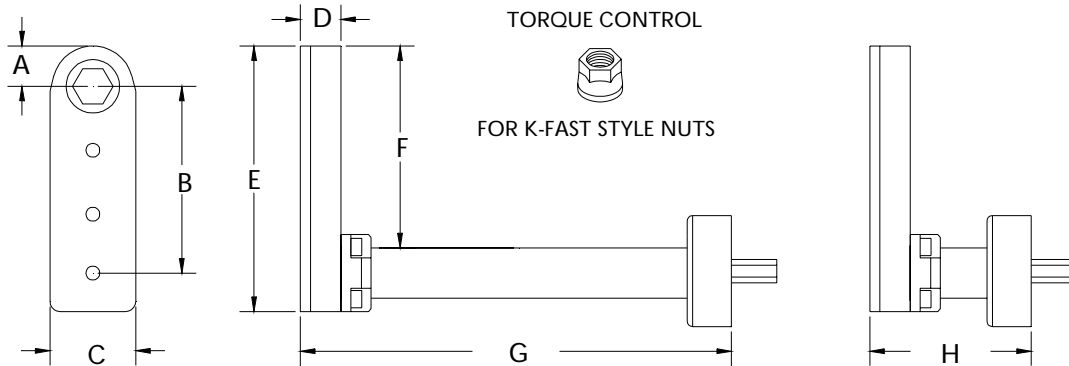

15895 ATTACHMENT ONLY EXTENDED

15896 ATTACHMENT ONLY SHORT

4 GEAR ATTACHMENTS REQUIRE REVERSE CAM MOTORS (SET TORQUE IN REVERSE)

TORQUE CONTROL L TOOLS			TORQUE RANGE		TOOL ORDER NUMBER	
MOTOR	RPM	REVERSIBLE	TORQUE INCH LB.	TORQUE Nm	WITH EXTENDED	WITH SHORT
.33 HP	175	YES	15 - 140	1.6 - 15.8	15879	15882
.45 HP	200	YES	20 - 160*	2.2 - 18.0*	15883	15884
.45 HP	400	YES	20 - 150	2.2 - 16.9	15885	15886

TOOL ORDER NUMBER PLUS  
NOSE GEAR NUMBER = COMPLETE TOOL

\*Maximum torque range of the motor exceeds  
the maximum torque range of the attachment

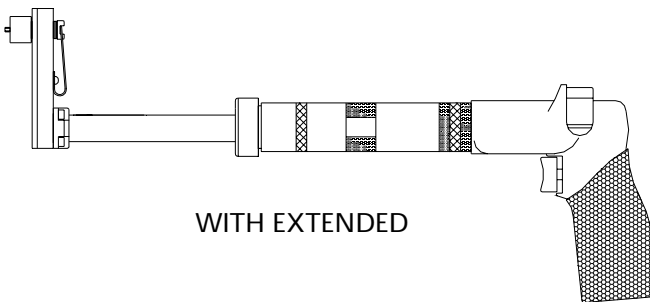

WITH EXTENDED

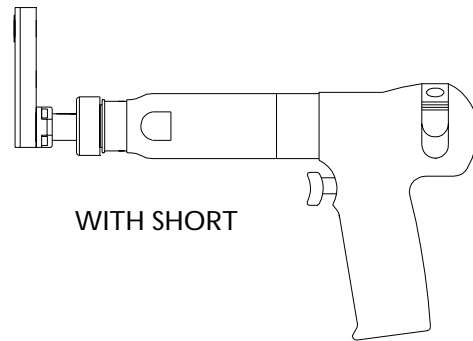

WITH SHORT

NOSE GEARS FOR SOCKETS.  
5/16 HEX DRIVER FOR HD SERIES 2 SOCKETS.

PART NO.	HEX SIZE	TYPE
15922	5/16	HEX DRIVER
15905	1/4	SQ. DRIVE MALE

FLUSH STYLE.  
THE SOCKET HEX IS BUILT INTO  
THE GEAR OF THE TOOL.  
NO SOCKET IS USED

PART NO.	HEX SIZE	TYPE
15889	11/32	HEX FLUSH
15890	3/8	HEX FLUSH
15891	7/16	HEX FLUSH
16038	5/16	HEX FLUSH

HEX THRU STYLE.  
HEX RUNS THROUGH NOSE GEAR.  
HEX KEY SPRING IS NOT SUPPLIED.

PART NO.	HEX SIZE	TYPE
15892	11/32	HEX THRU
15893	3/8	HEX THRU
15894	7/16	HEX THRU
16039	5/16	HEX THRU