

# SERIES 2 EXTENDED ATTACHMENTS WITH TORQUE CONTROL MOTORS

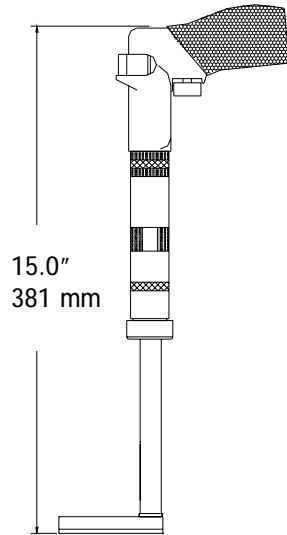

5



CLECO 5 .33 HP MOTOR  
175 R.P.M. REVERSIBLE  
WEIGHT: 2.8 LBS.  
1.27 KG.

5

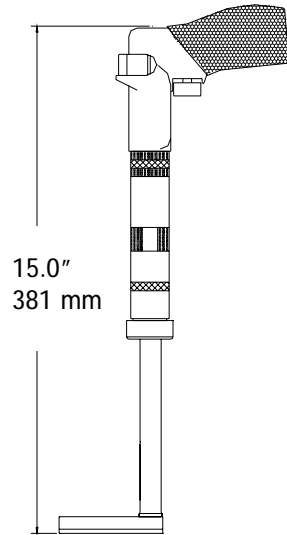

CLECO 5 .33 HP MOTOR  
420 R.P.M. REVERSIBLE  
WEIGHT: 2.8 LBS.  
1.27 Kg.

8

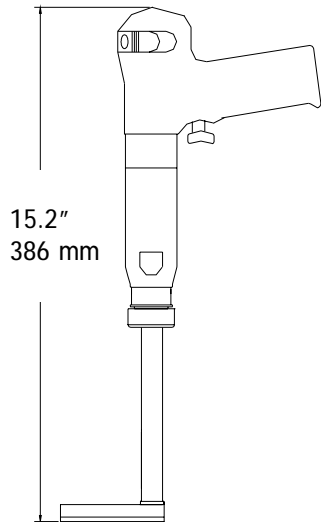

CLECO 8 .45 HP MOTOR  
200 R.P.M. REVERSIBLE  
WEIGHT: 4.4 LBS.  
2.00 Kg.

8

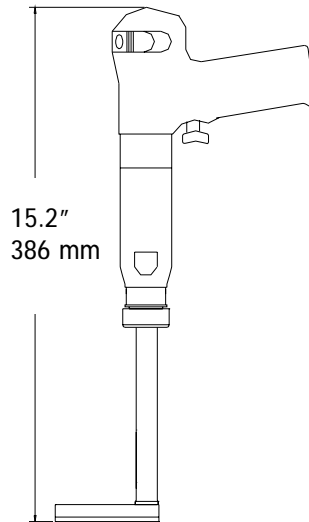

CLECO 8 .45 HP MOTOR  
400 R.P.M. REVERSIBLE  
WEIGHT: 4.4 LBS.  
2.00 Kg.