

HIGH OUTPUT

	A	B	C	D	E	F	G	H	SERIES 1 L INSTALLATION	
INCH	.317	1.187	.750	.250	2.437	3.282	6.300	2.000	MAXIMUM RECOMMENDED FASTENER TORQUE	60 INCH LBS.
MM	8.05	30.14	19.05	6.35	61.89	83.36	160.0	50.80		6.77 Nm

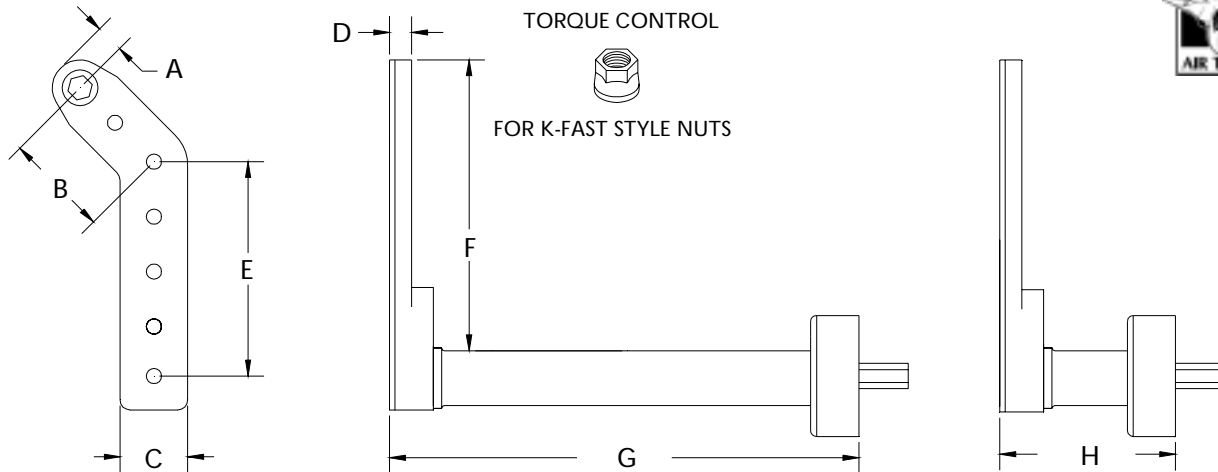

13198 ATTACHMENT ONLY EXTENDED

13199 ATTACHMENT ONLY SHORT

TORQUE CONTROL L TOOLS			TORQUE RANGE		TOOL ORDER NUMBERS	
MOTOR	RPM	REVERSIBLE	TORQUE INCH LB.	TORQUE Nm	WITH EXTENDED	WITH SHORT
.33 HP	175	YES	5 - 60*	.5 - 6.7*	13334	13335
.33 HP	420	YES	5 - 52	.5 - 5.8	13336	13337
.45 HP	200	YES	8 - 60*	.9 - 6.7*	13338	13339
.45 HP	400	YES	8 - 60*	.9 - 6.7*	13340	13341

TOOL ORDER NUMBER PLUS
NOSE GEAR NUMBER = COMPLETE TOOL

*Maximum torque range of the motor exceeds
the maximum torque range of the attachment

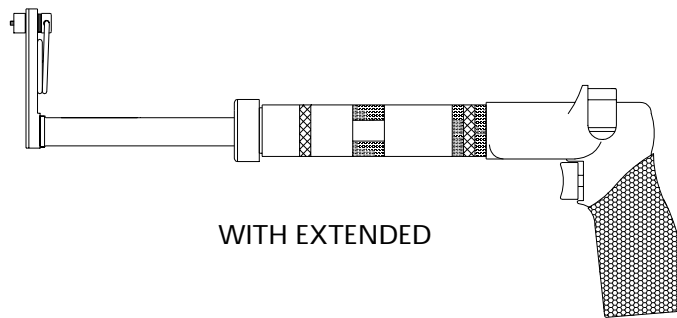

WITH EXTENDED

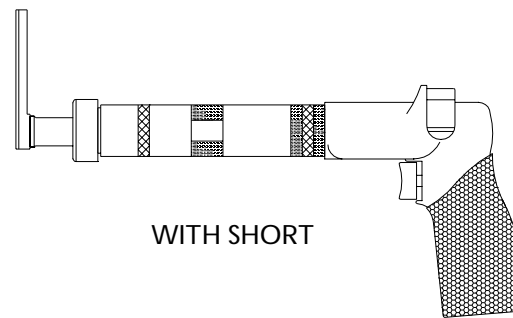

WITH SHORT

NOSE GEARS FOR SOCKETS.
HEX DRIVER FOR HO SERIES 1 SOCKETS

PART NO.	SIZE	TYPE
12465	9/32	HEX DRIVER
13186	1/4	SQ DRIVE MALE

HEX THRU STYLE.
HEX RUNS THROUGH NOSE GEAR.
HEX KEY SPRING IS NOT SUPPLIED.

PART NO.	HEX SIZE	TYPE
12657	7/32	HEX THRU
13187	1/4	HEX THRU
13188	9/32	HEX THRU

FOR TWELVE POINT CONFIGURATION
ADD X TO NOSE GEAR PART No.