

# SERIES 1 EXTENDED ATTACHMENTS WITH TORQUE CONTROL MOTORS

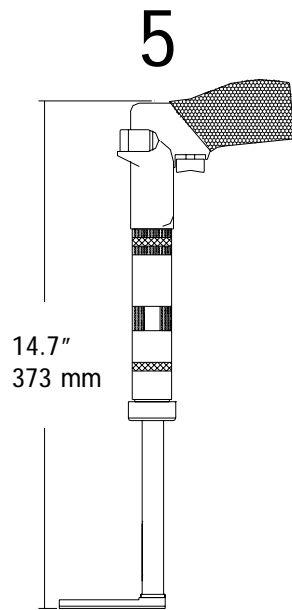

**CLECO 5 .33 HP MOTOR**  
175 R.P.M. REVERSIBLE  
WEIGHT: 2.6 LBS.  
1.18 Kg.

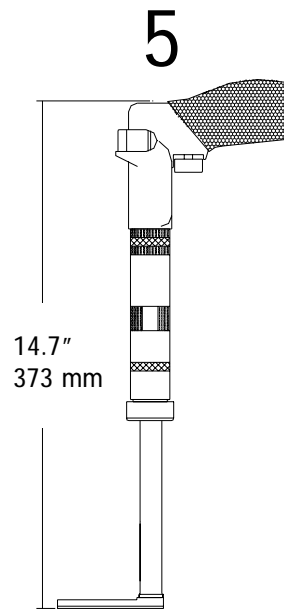

**CLECO 5 .33 HP MOTOR**  
420 R.P.M. REVERSIBLE  
WEIGHT: 2.6 LBS.  
1.18 Kg.

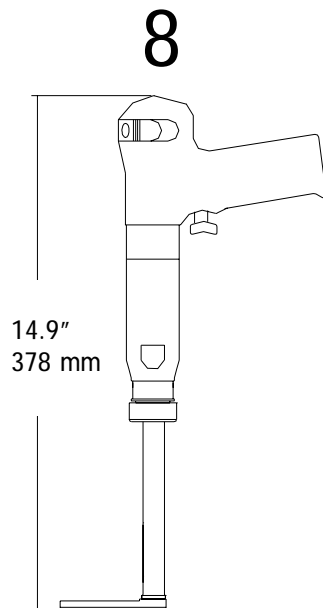

**CLECO 8 .45 HP MOTOR**  
200 R.P.M. REVERSIBLE  
WEIGHT: 4.2 LBS.  
1.90 Kg.

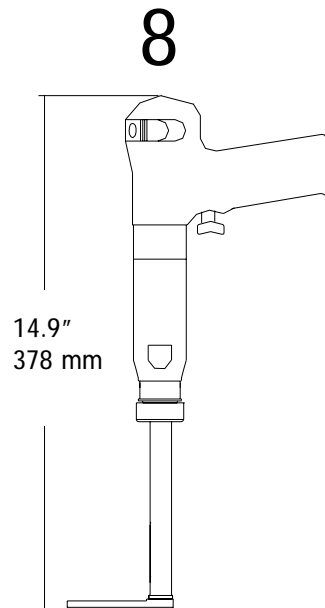

**CLECO 8 .45 HP MOTOR**  
400 R.P.M. REVERSIBLE  
WEIGHT: 4.2 LBS.  
1.90 Kg.