

HIGH OUTPUT

	A	B	C	D	E	F	G	H	SERIES 3 L INSTALLATION	
INCH	.562	3.543	1.125	.687	4.582	3.762	6.500	2.180	MAXIMUM RECOMMENDED FASTENER TORQUE	200 INCH LBS.
MM	14.27	89.99	28.57	17.44	116.3	95.55	165.1	55.37		22.59 Nm

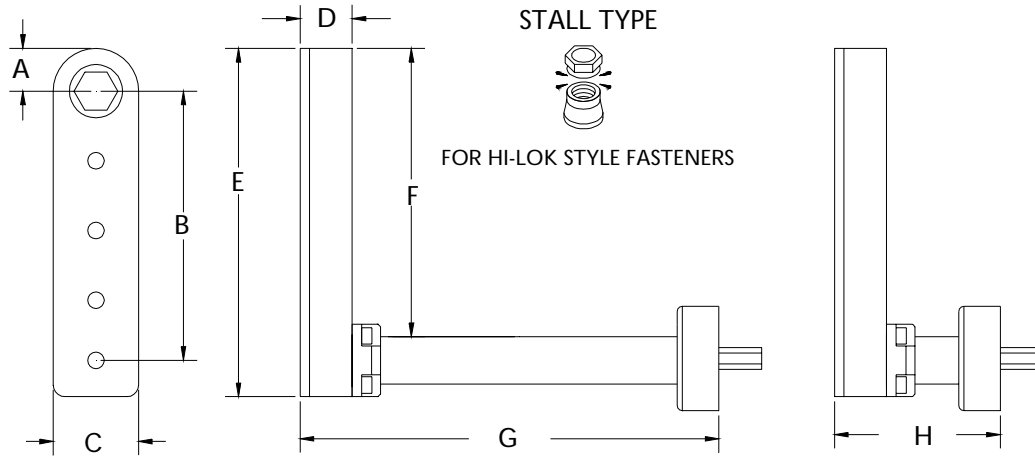

13218 ATTACHMENT ONLY EXTENDED

13219 ATTACHMENT ONLY SHORT

STALL TYPE L TOOLS			OUTPUT AT FASTENER		TOOL ORDER NUMBERS	
MOTOR	RPM	REVERSIBLE	TORQUE INCH LB.	TORQUE Nm	WITH EXTENDED	WITH SHORT
.40 HP	250	YES	200*	22.5*	13562	13563
.40 HP	450	YES	150	16.9	13564	13565
.45 HP	400	YES	160	18.0	13566	13567
.60 HP	250	NO	200*	22.5*	13568	13569
.60 HP	450	NO	200*	22.5*	13570	13571

TOOL ORDER NUMBER PLUS
NOSE GEAR NUMBER = COMPLETE TOOL

*Maximum torque range of the motor exceeds
the maximum torque range of the attachment

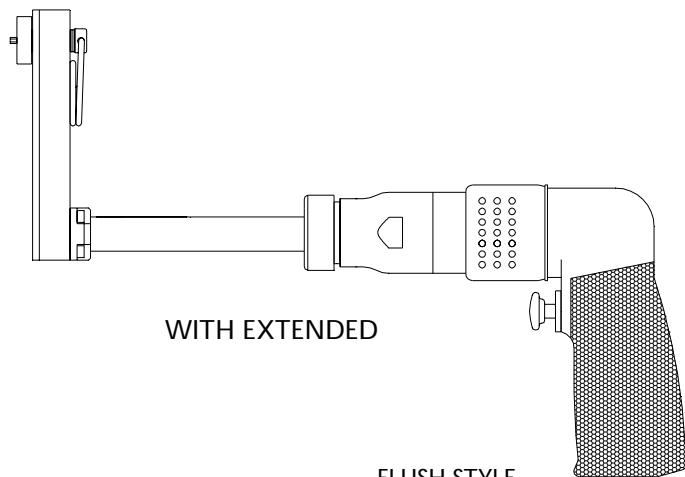

WITH EXTENDED

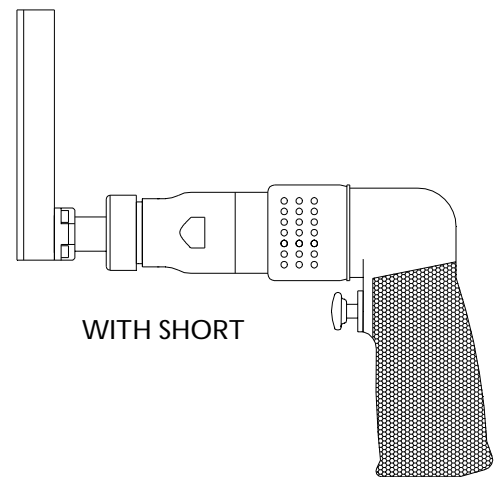

WITH SHORT

NOSE GEARS FOR SOCKETS.
HEX DRIVER FOR UAT SOCKET SYSTEM.

PART NO.	SIZE	TYPE
12479	3/8	HEX DRIVER
12480	3/8	SQ DRIVE MALE

FLUSH STYLE.
THE SOCKET HEX IS BUILT INTO
THE GEAR OF THE TOOL.
NO SOCKET IS USED

PART NO.	HEX SIZE	TYPE
12481	5/16	HEX FLU SH
12482	11/32	HEX FLU SH
12483	3/8	HEX FLU SH
12484	7/16	HEX FLU SH
12485	1/2	HEX FLU SH

HEX THRU STYLE.
HEX RUNS THROUGH NOSE GEAR.
HEX KEY SPRING IS NOT SUPPLIED.

PART NO.	HEX SIZE	TYPE
12486	5/16	HEX THRU
12487	11/32	HEX THRU
12488	3/8	HEX THRU
12489	7/16	HEX THRU
12490	1/2	HEX THRU