

SERIES 3 EXTENDED ATTACHMENTS WITH STALL MOTORS

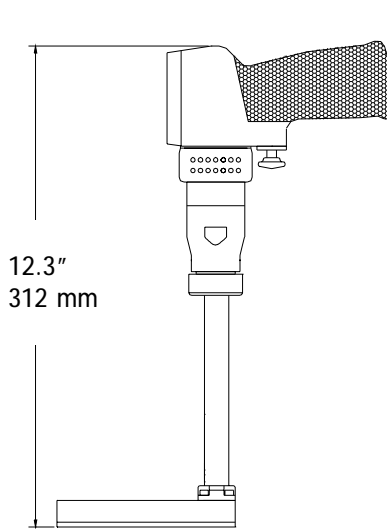

RD2



RD2 SERIES .40 HP MOTOR
450 R.P.M. REVERSIBLE
WEIGHT: 3.6 LBS.
1.63 Kg

RD2

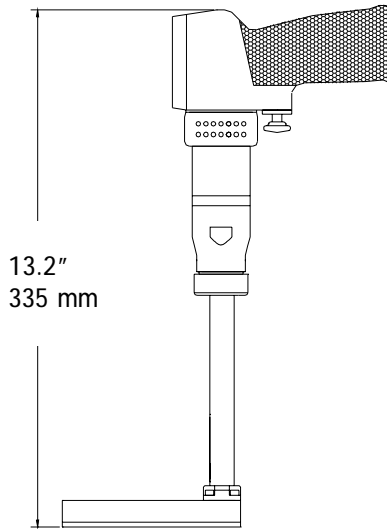

RD2 SERIES .40 HP MOTOR
250 R.P.M. REVERSIBLE
WEIGHT: 4.0 LBS.
1.81 Kg.

8

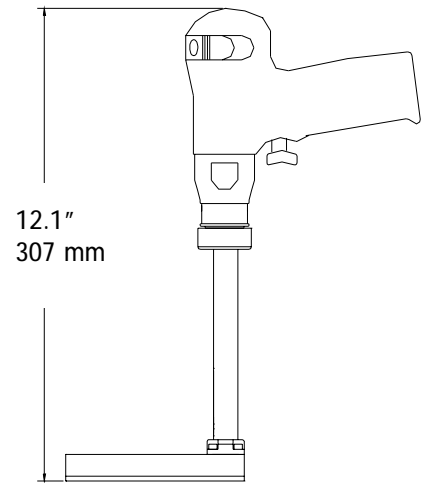

CLECO 8 .45 HP MOTOR
400 R.P.M. REVERSIBLE
WEIGHT: 3.2 LBS.
1.45 Kg.

D2

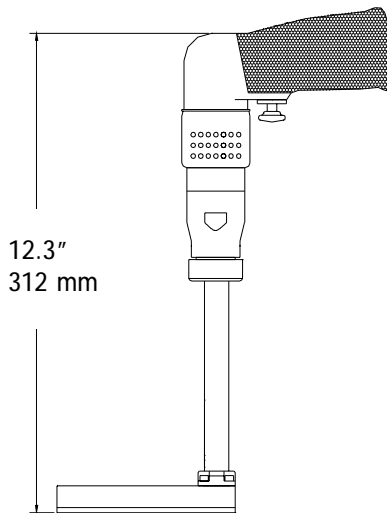

D2 .60 HP MOTOR
450 R.P.M.
WEIGHT: 3.2 LBS.
1.45 Kg.

D2

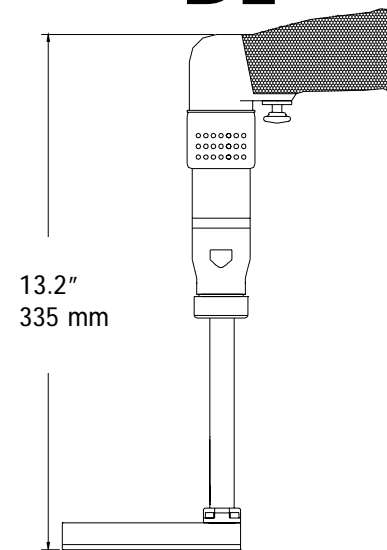

D2 .60 HP MOTOR
250 R.P.M.
WEIGHT: 3.6 LBS.
1.63 Kg.