

HIGH OUTPUT

	A	B	C	D	E	F	G	H	SERIES 2 L INSTALLATION	
INCH	.317	4.812	.750	.500	5.514	4.817	6.425	2.125	MAXIMUM RECOMMENDED FASTENER TORQUE	120 INCH LBS.
MM	8.05	122.2	19.05	12.70	140.0	122.3	163.1	53.97		13.55 Nm

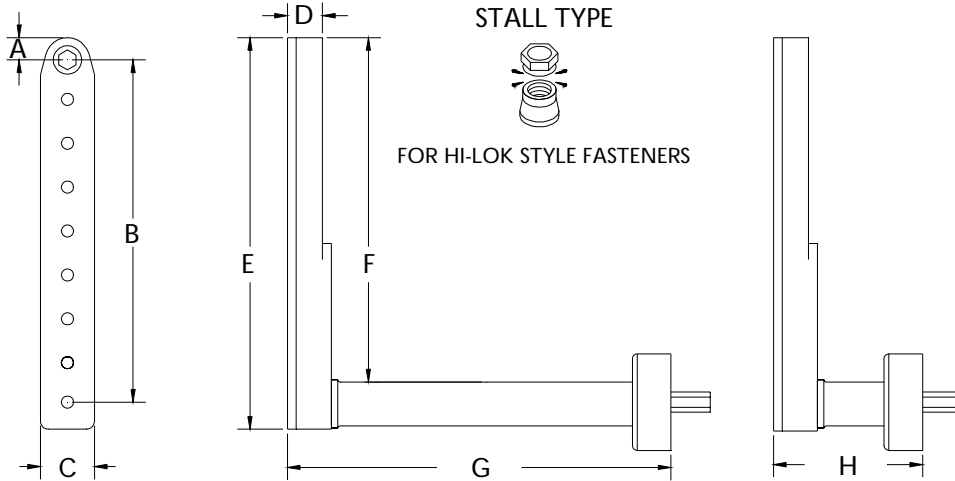

13208 ATTACHMENT ONLY EXTENDED

13209 ATTACHMENT ONLY SHORT

STALL TYPE L TOOLS			OUTPUT AT FASTENER		TOOL ORDER NUMBERS	
MOTOR	RPM	REVERSIBLE	TORQUE INCH LB.	TORQUE Nm	WITH EXTENDED	WITH SHORT
.30 HP	250	NO	54	6.1	13474	13475
.33 HP	260	YES	63	7.1	13476	13477
.40 HP	250	YES	72	8.1	13478	13479
.40 HP	450	YES	54	6.1	13480	13481
.45 HP	400	YES	57	6.4	13482	13483
.60 HP	250	NO	108	12.2	13484	13485
.60 HP	450	NO	90	10.1	13486	13487

TOOL ORDER NUMBER PLUS
NOSE GEAR NUMBER = COMPLETE TOOL

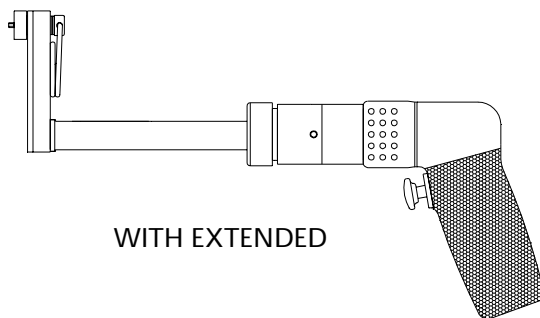

WITH EXTENDED

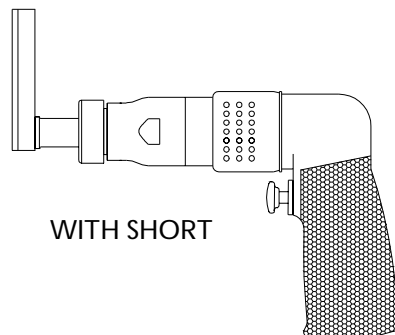

WITH SHORT

NOSE GEARS FOR SOCKETS.
HEX DRIVER FOR HO SERIES 2 SOCKETS

PART NO.	SIZE	TYPE
12467	9/32	HEX DRIVER
12468	1/4	SQ DRIVE MALE

THE SOCKET HEX IS BUILT INTO
THE GEAR OF THE TOOL.
NO SOCKET IS USED

PART NO.	HEX SIZE	TYPE
12469	7/32	HEX FLUSH
12470	1/4	HEX FLUSH
12471	9/32	HEX FLUSH

HEX THRU STYLE.
HEX RUNS THROUGH NOSE GEAR.
HEX KEY SPRING IS NOT SUPPLIED.

PART NO.	HEX SIZE	TYPE
12474	3/16	HEX THRU
12475	7/32	HEX THRU
12476	1/4	HEX THRU
12477	9/32	HEX THRU