

	A	B	C	D	E	F	G	H	SERIES 2 HW L INSTALLATION	
INCH	.500	4.690	1.062	.500	5.666	4.878	6.300	2.000	MAXIMUM RECOMMENDED FASTENER TORQUE	160 INCH LBS.
MM	12.7	119.1	26.97	12.70	143.9	123.9	160.0	50.80		18.07 Nm

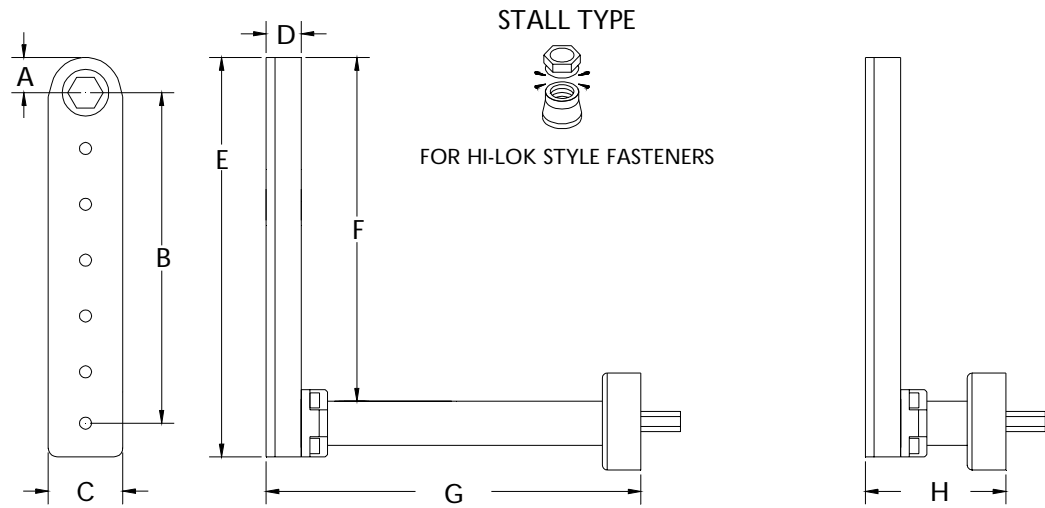

16040 ATTACHMENT ONLY EXTENDED

16041 ATTACHMENT ONLY SHORT

STALL TYPE L TOOLS			OUTPUT AT FASTENER		TOOL ORDER NUMBERS	
MOTOR	RPM	REVERSIBLE	TORQUE INCH LB.	TORQUE Nm	WITH EXTENDED	WITH SHORT
.40 HP	250	YES	150	16.9	16042	16043
.40 HP	450	YES	110	12.4	16044	16045
.60 HP	250	NO	160*	18.0*	16046	16047
.60 HP	450	NO	160*	18.0*	16048	16049

TOOL ORDER NUMBER PLUS
NOSE GEAR NUMBER = COMPLETE TOOL

*Maximum torque range of the motor exceeds
the maximum torque range of the attachment

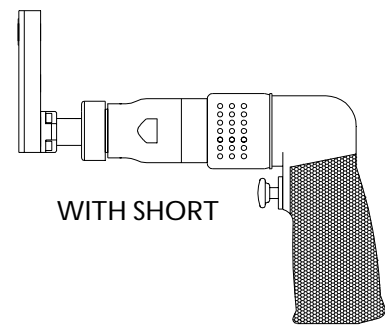
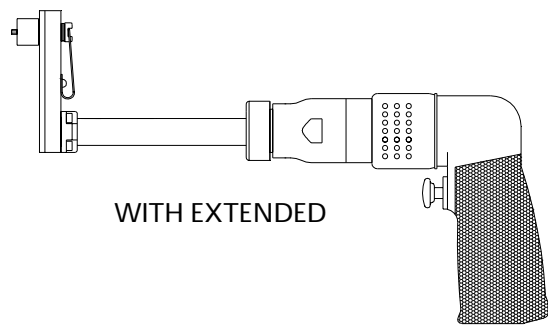

NOSE GEARS FOR SOCKETS.
5/16 HEX DRIVER FOR HD SERIES 2 SOCKETS.
5/16 HEX DRIVER FOR EDDIE BOLT SOCKETS.

PART NO.	HEX SIZE	TYPE
15922	5/16	HEX DRIVER
15905	1/4	SQ. DRIVE MALE

FLUSH STYLE.
THE SOCKET HEX IS BUILT INTO
THE GEAR OF THE TOOL.
NO SOCKET IS USED

PART NO.	HEX SIZE	TYPE
15889	11/32	HEX FLUSH
15890	3/8	HEX FLUSH
15891	7/16	HEX FLUSH
16038	5/16	HEX FLUSH

HEX THRU STYLE.
HEX RUNS THROUGH NOSE GEAR.
HEX KEY SPRING IS NOT SUPPLIED.

PART NO.	HEX SIZE	TYPE
15892	11/32	HEX THRU
15893	3/8	HEX THRU
15894	7/16	HEX THRU
16039	5/16	HEX THRU

*"EDDIE BOLT" IS A TRADEMARK OF THE FAIRCHILD CORPORATION