

HIGH OUTPUT

	A	B	C	D	E	F	G	H	SERIES 2 L INSTALLATION	
INCH	.317	1.750	.750	.500	2.452	1.755	6.300	2.000	MAXIMUM RECOMMENDED FASTENER TORQUE	120 INCH LBS.
MM	8.05	44.45	19.05	12.70	62.28	44.57	160.0	50.80		13.55 Nm

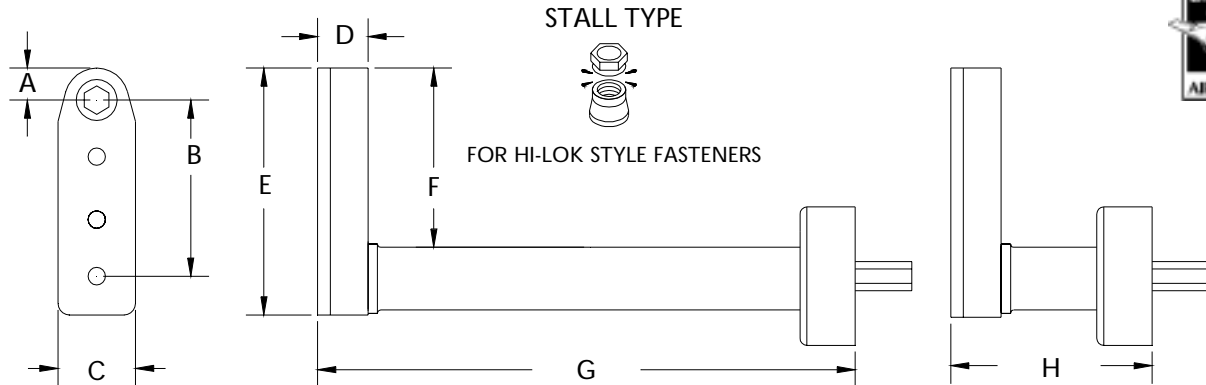

13204 ATTACHMENT ONLY EXTENDED

13205 ATTACHMENT ONLY SHORT

4 GEAR ATTACHMENTS REQUIRE REVERSE RUNNING (K) OR REVERSIBLE MOTORS

STALL TYPE L TOOLS			OUTPUT AT FASTENER		TOOL ORDER NUMBERS	
MOTOR	RPM	REVERSIBLE	TORQUE INCH LB.	TORQUE Nm	WITH EXTENDED	WITH SHORT
.30 HP	250	NO	114	12.8	13408	13409
.30 HP	500	NO	76	8.5	15440	15441
.33 HP	260	YES	120*	13.5*	13410	13411
.40 HP	250	YES	120*	13.5*	13412	13413
.40 HP	450	YES	114	12.8	13414	13415
.45 HP	400	YES	120*	13.5*	13416	13417
.60 HP	250	NO	120*	13.5*	13418	13419
.60 HP	450	NO	120*	13.5*	13420	13421

TOOL ORDER NUMBER PLUS
NOSE GEAR NUMBER = COMPLETE TOOL

*Maximum torque range of the motor exceeds
the maximum torque range of the attachment

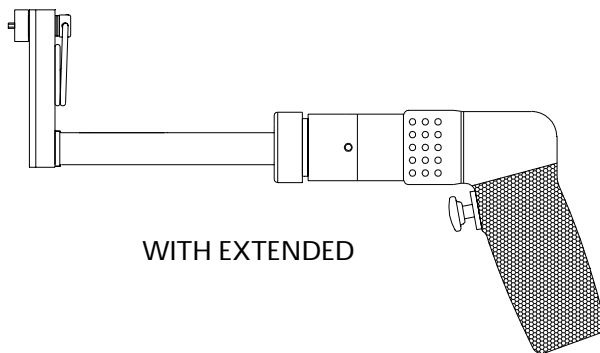

WITH EXTENDED

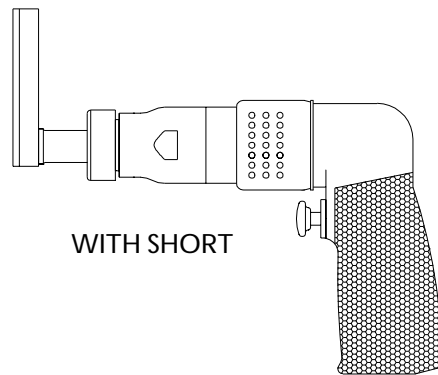

WITH SHORT

NOSE GEARS FOR SOCKETS.
HEX DRIVER FOR HO SERIES 2 SOCKETS

PART NO.	SIZE	TYPE
12467	9/32	HEX DRIVER
12468	1/4	SQ DRIVE MALE

FLUSH STYLE.
THE SOCKET HEX IS BUILT INTO
THE GEAR OF THE TOOL.
NO SOCKET IS USED

PART NO.	HEX SIZE	TYPE
12469	7/32	HEX FLUSH
12470	1/4	HEX FLUSH
12471	9/32	HEX FLUSH

HEX THRU STYLE.
HEX RUNS THROUGH NOSE GEAR.
HEX KEY SPRING IS NOT SUPPLIED.

PART NO.	HEX SIZE	TYPE
12474	3/16	HEX THRU
12475	7/32	HEX THRU
12476	1/4	HEX THRU
12477	9/32	HEX THRU