

HIGH OUTPUT

	A	B	C	D	E	F	G	H	SERIES 1 L INSTALLATION	
INCH	.317	4.812	.750	.250	5.514	4.817	6.300	2.000	MAXIMUM RECOMMENDED FASTENER TORQUE	60 INCH LBS.
MM	8.05	122.2	19.05	6.35	140.0	122.3	160.0	50.80		6.77 Nm

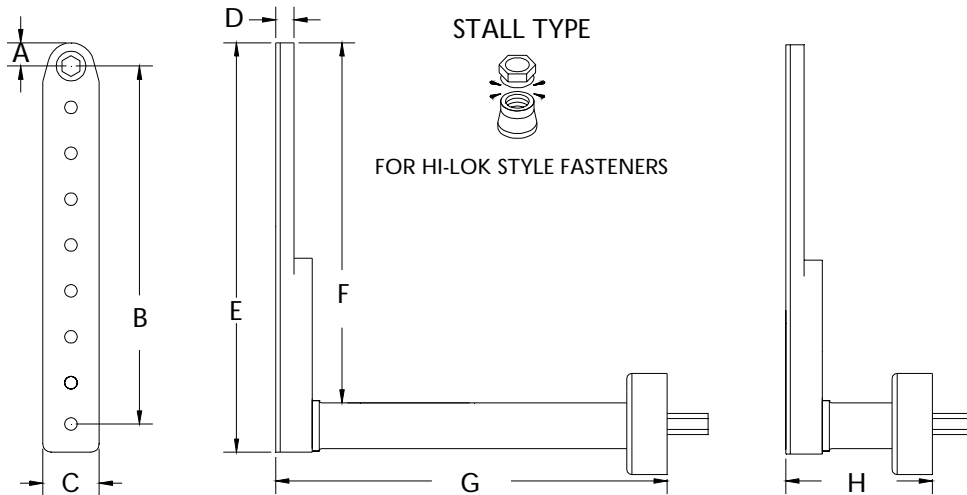

13196 ATTACHMENT ONLY EXTENDED

13197 ATTACHMENT ONLY SHORT

STALL TYPE L TOOLS			OUTPUT AT FASTENER		TOOL ORDER NUMBERS	
MOTOR	RPM	REVERSIBLE	TORQUE INCH LB.	TORQUE Nm	WITH EXTENDED	WITH SHORT
.30 HP	250	NO	54	6.1	13320	13321
.33 HP	260	YES	60*	6.7*	13322	13323
.40 HP	250	YES	60*	6.7*	13324	13325
.40 HP	450	YES	60*	6.7*	13326	13327
.45 HP	400	YES	60*	6.7*	13328	13329
.60 HP	250	NO	60*	6.7*	13330	13331
.60 HP	450	NO	60*	6.7*	13332	13333

TOOL ORDER NUMBER PLUS
NOSE GEAR NUMBER = COMPLETE TOOL

*Maximum torque range of the motor exceeds the maximum torque range of the attachment

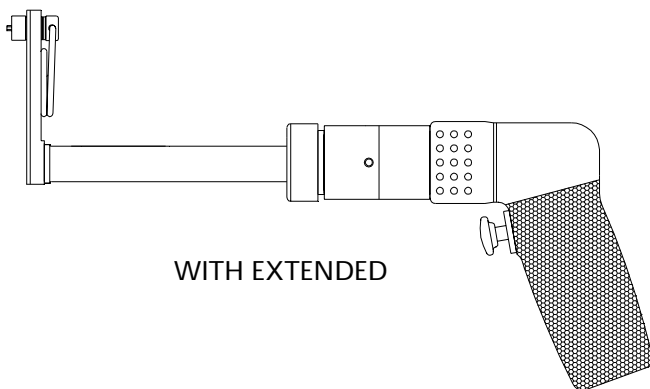

WITH EXTENDED

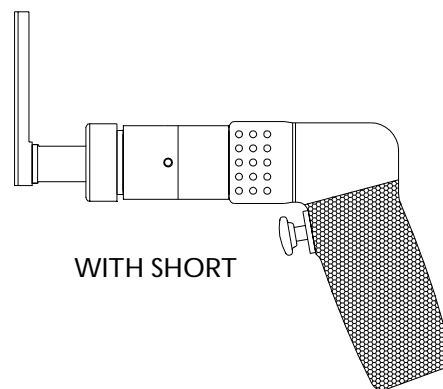

WITH SHORT

NOSE GEARS FOR SOCKETS.
HEX DRIVER FOR UAT SERIES 1
HO SOCKETS

PART NO.	SIZE	TYPE
12465	9/32	HEX DRIVER
13186	1/4	SQ DRIVE MALE

HEX THRU STYLE.
HEX RUNS THROUGH NOSE GEAR.
HEX KEY SPRING IS NOT SUPPLIED.

PART NO.	HEX SIZE	TYPE
12657	7/32	HEX THRU
13187	1/4	HEX THRU
13188	9/32	HEX THRU