

	A	B	C	D	E	F	G	H	SERIES 2 17 DEG INSTALLATION	
INCH	.500	2.32	3.24	.770	1.02	.317	1.77	1.10	MAXIMUM RECOMMENDED FASTENER TORQUE	120 INCH LBS.
MM	12.7	58.9	82.2	19.5	25.9	8.05	44.9	27.9		13.55 Nm

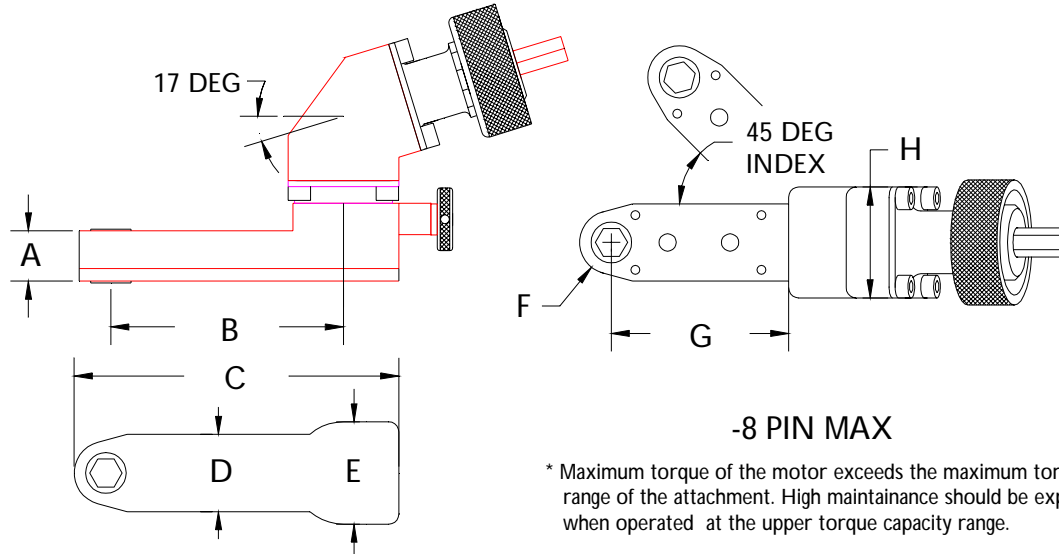

STALL TYPE 15357 ATTACHMENT ONLY 17 DEGREE SERIES 2 MODULAR INSTALLATION



-8 PIN MAX

* Maximum torque of the motor exceeds the maximum torque range of the attachment. High maintenance should be expected when operated at the upper torque capacity range.

STALL TYPE 17 DEGREE TOOLS				OUTPUT AT FASTENER		TOOL ORDER NUMBER
MOTOR	RPM	REVERSIBLE	TYPE	TORQUE INCH LB.	TORQUE Nm	
.30	250	NO	SD	120*	13.5*	15405
.30	500	NO	SD	119	13.4	15406
.40	250	YES	SRD1	120*	13.5*	15407
.40	450	YES	SRD1	102	11.5	15408
.60	250	NO	SD2	120*	13.5*	15409
.60	450	NO	SD2	120*	13.5*	15410

TOOL LENGTH			
RPM	TYPE	INCH	MM
250	SD	10.5	266
500	SD	10.5	266
250	SRD1	11.8	299
450	SRD1	10.9	276
250	SD2	11.8	299
450	SD2	10.9	276

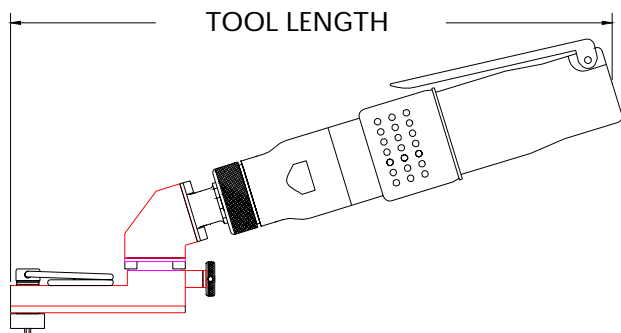

NOSE GEARS FOR SOCKETS.
HEX DRIVER FOR HO SERIES 2 SOCKETS

PART NO.	SIZE	TYPE
12467	9/32	HEX DRIVER
12468	1/4	SQ DRIVE MALE

FLUSH STYLE.
THE SOCKET HEX IS BUILT INTO
THE GEAR OF THE TOOL.
NO SOCKET IS USED.

PART NO.	HEX SIZE	TYPE
12469	7/32	HEX FLU SH
12470	1/4	HEX FLU SH
12471	9/32	HEX FLU SH

HEX THRU STYLE.
HEX RUNS THROUGH NOSE GEAR.
HEX KEY SPRING IS NOT SUPPLIED.

PART NO.	HEX SIZE	TYPE
12474	3/16	HEX THRU
12475	7/32	HEX THRU
12476	1/4	HEX THRU
12477	9/32	HEX THRU