

	A	B	C	D	E	F	G	H	SERIES 1 17 DEG INSTALLATION	
INCH	.250	2.32	3.24	.770	1.02	.317	1.77	1.10	MAXIMUM RECOMMENDED FASTENER TORQUE	55 INCH LBS.
MM	6.35	58.9	82.2	19.5	25.9	8.05	44.9	27.9		6.2 Nm

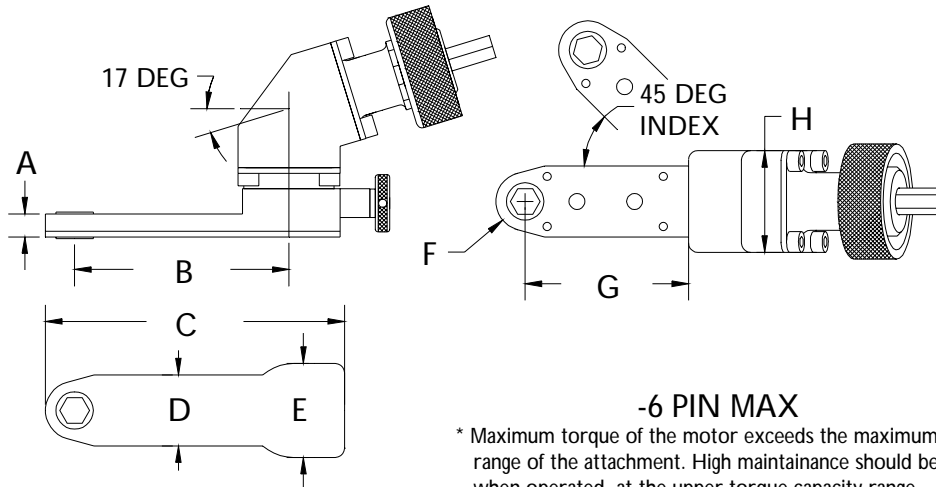

**STALL TYPE
15356 ATTACHMENT ONLY
17 DEGREE SERIES 1 MODULAR INSTALLATION**



* Maximum torque of the motor exceeds the maximum torque range of the attachment. High maintainance should be expected when operated at the upper torque capacity range.

STALL TYPE 17 DEGREE TOOLS				OUTPUT AT FASTENER		TOOL ORDER NUMBER
MOTOR	RPM	REVERSIBLE	TYPE	TORQUE INCH LB.	TORQUE Nm	
.30	250	NO	SD	55*	6.2*	15399
.30	500	NO	SD	55*	6.2*	15400
.40	250	YES	SRD1	55*	6.2*	15401
.40	450	YES	SRD1	55*	6.2*	15402
.60	250	NO	SD2	55*	6.2*	15403
.60	450	NO	SD2	55*	6.2*	15404

TOOL LENGTH			
RPM	TYPE	INCH	MM
250	SD	10.5	266
500	SD	10.5	266
250	SRD1	11.8	299
450	SRD1	10.9	276
250	SD2	11.8	299
450	SD2	10.9	276

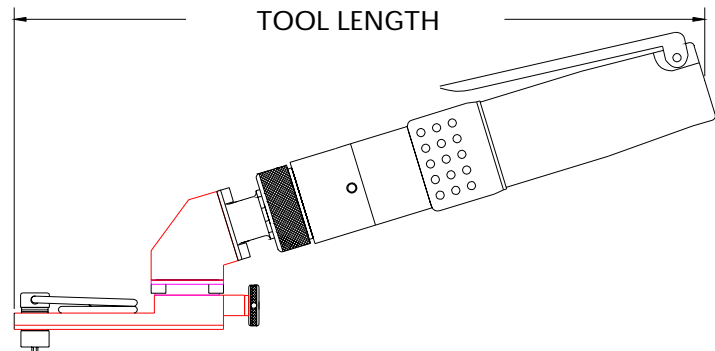

NOSE GEARS FOR SOCKETS.
HEX DRIVER FOR HO SERIES 1 SOCKETS

PART NO.	SIZE	TYPE
12465	9/32	HEX DRIVER
13186	1/4	SQ DRIVE MALE

HEX THRU STYLE.
HEX RUNS THROUGH NOSE GEAR.
HEX KEY SPRING IS NOT SUPPLIED.

PART NO.	HEX SIZE	TYPE
12657	7/32	HEX THRU
13187	1/4	HEX THRU
13188	9/32	HEX THRU
13189	5/16	HEX THRU