

	A	B	C	D	E	F	G	SERIES 3 L DRILL	
INCH	.327	1.109	.900	.425	2.250	3.106	1.933	MAXIMUM RECOMMENDED DRILL DIAMETER	.312 INCH
MM	8.30	28.16	22.86	10.79	57.15	78.89	49.09		7.92 mm

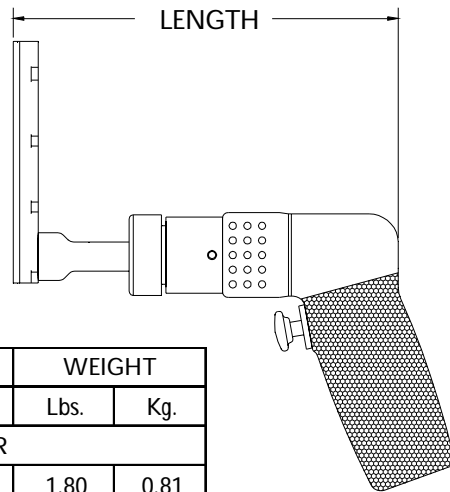

13835 ATTACHMENT ONLY SHORT

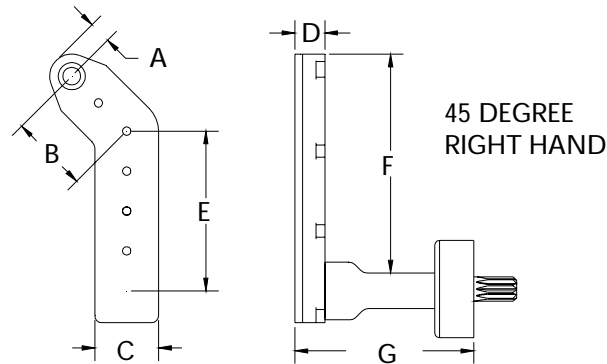

TOOL ORDER NUMBER	R.P.M.	LENGTH		WEIGHT	
		Inch	mm	Lbs.	Kg.
D SERIES .30 HP MOTOR					
16395	250	7.15	181.6	1.80	0.81
14693	500	7.15	181.6	1.80	0.81
14694	750	7.15	181.6	1.80	0.81
14695	1000	7.15	181.6	1.80	0.81
14696	1500	7.15	181.6	1.80	0.81
14697	2800	6.25	158.7	1.52	0.68
D2 SERIES .60 HP MOTOR					
16396	250	8.85	224.7	3.37	1.53
14698	450	8.25	209.5	2.67	1.21
14699	1000	8.25	209.5	2.67	1.21
14700	2000	7.00	177.8	2.42	1.09
14701	2700	7.00	177.8	2.42	1.09
14702	3500	7.00	177.8	2.42	1.09
RD2 .40 HP REVERSIBLE MOTOR					
16397	250	8.85	224.7	3.37	1.53
14703	450	8.25	209.5	2.92	1.32
14704	1000	8.25	209.5	2.92	1.32
14705	2000	7.00	177.8	2.67	1.21
14706	2700	7.00	177.8	2.67	1.21
14707	3500	7.00	177.8	2.67	1.21

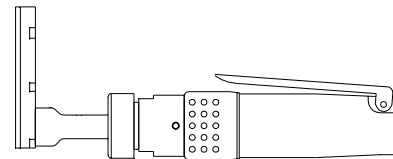

Add an S after the tool order number for the straight handle option.

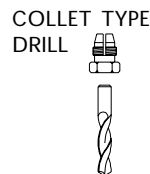

INTERNAL THREAD	
ADD TO TOOL No.	
1/4-28	A
10-32	C
9/32-40	E
5/16-24	F
COLLET	D

PHONE: 1 775 883 1072 FAX: 1 775 883 4857