

	A	B	C	D	E	F	G	SERIES 3 L DRILL	
INCH	.327	3.359	.900	.425	4.127	3.427	6.263	MAXIMUM RECOMMENDED DRILL DIAMETER	.312 INCH
MM	8.30	85.31	22.86	10.79	104.8	87.04	159.0		7.92 mm

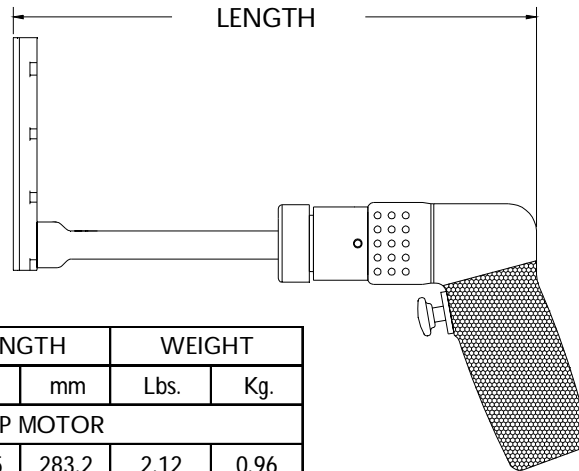

13832 ATTACHMENT ONLY EXTENDED

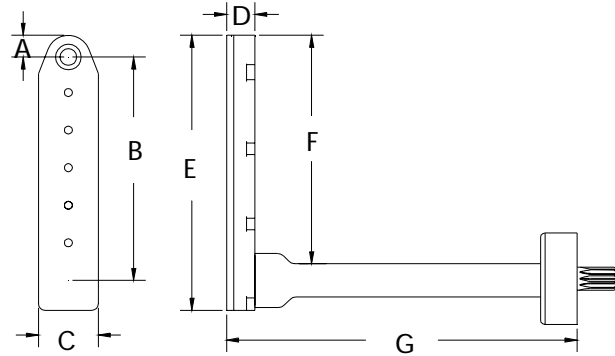

TOOL ORDER NUMBER	R.P.M.	LENGTH		WEIGHT	
		Inch	mm	Lbs.	Kg.
D SERIES .30 HP MOTOR					
16386	250	11.15	283.2	2.12	0.96
14648	500	11.15	283.2	2.12	0.96
14649	750	11.15	283.2	2.12	0.96
14650	1000	11.15	283.2	2.12	0.96
14651	1500	11.15	283.2	2.12	0.96
14652	2800	10.25	260.3	1.84	0.83
D2 SERIES .60 HP MOTOR					
16387	250	13.10	332.7	3.69	1.67
14653	450	12.50	317.5	2.99	1.35
14654	1000	12.50	317.5	2.99	1.35
14655	2000	11.25	285.7	2.74	1.24
14656	2700	11.25	285.7	2.74	1.24
14657	3500	11.25	285.7	2.74	1.24
RD2 .40 HP REVERSIBLE MOTOR					
16388	250	13.10	332.7	3.69	1.67
14658	450	12.50	317.5	3.24	1.46
14659	1000	12.50	317.5	3.24	1.46
14660	2000	11.25	285.7	2.99	1.35
14661	2700	11.25	285.7	2.99	1.35
14662	3500	11.25	285.7	2.99	1.35

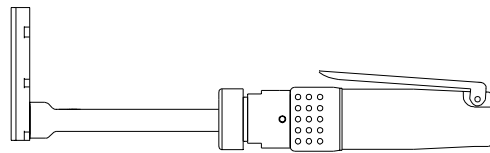

Add an S after the tool order number for the straight handle option.

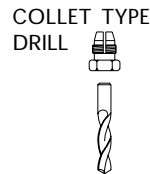

INTERNAL THREAD	
ADD TO TOOL No.	
1/4-28	A
10-32	C
9/32-40	E
5/16-24	F
COLLET	D