

	A	B	C	D	E	F	G	SERIES 3 L DRILL	
INCH	.327	2.234	.900	.425	3.00	2.302	1.933	MAXIMUM RECOMMENDED DRILL DIAMETER	.312 INCH
MM	8.30	56.74	22.86	10.79	76.20	58.47	49.09		7.92 mm

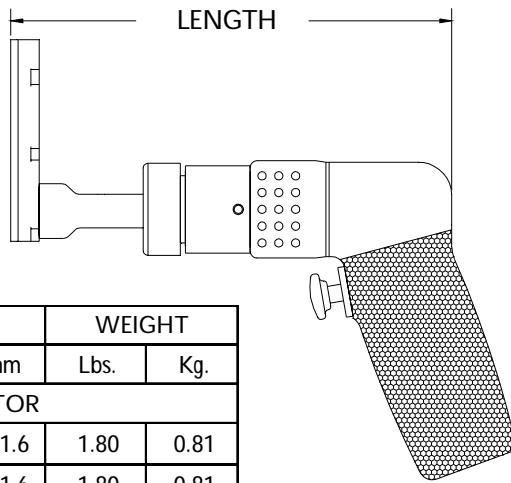

13831 ATTACHMENT ONLY SHORT

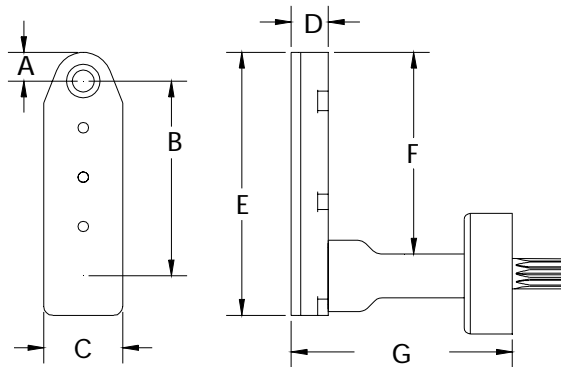

TOOL ORDER NUMBER	R.P.M.	LENGTH		WEIGHT	
		Inch	mm	Lbs.	Kg.
D SERIES .30 HP MOTOR					
16383	250	7.15	181.6	1.80	0.81
14633	500	7.15	181.6	1.80	0.81
14634	750	7.15	181.6	1.80	0.81
14635	1000	7.15	181.6	1.80	0.81
14636	1500	7.15	181.6	1.80	0.81
14637	2800	6.25	158.7	1.52	0.68
D2 SERIES .60 HP MOTOR					
16384	250	8.85	224.7	3.37	1.53
14638	450	8.25	209.5	2.67	1.21
14639	1000	8.25	209.5	2.67	1.21
14640	2000	7.00	177.8	2.42	1.09
14641	2700	7.00	177.8	2.42	1.09
14642	3500	7.00	177.8	2.42	1.09
RD2 .40 HP REVERSIBLE MOTOR					
16385	250	8.85	224.7	3.37	1.53
14643	450	8.25	209.5	2.92	1.32
14644	1000	8.25	209.5	2.92	1.32
14645	2000	7.00	177.8	2.67	1.21
14646	2700	7.00	177.8	2.67	1.21
14647	3500	7.00	177.8	2.67	1.21

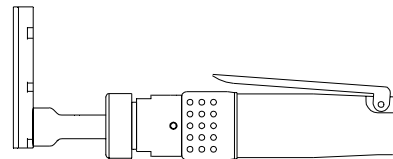

Add an S after the tool order number for the straight handle option.

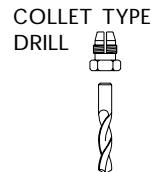

INTERNAL THREAD	
ADD TO TOOL No.	
1/4-28	A
10-32	C
9/32-40	E
5/16-24	F
COLLET	D

PHONE: 1 775 883 1072 FAX: 1 775 883 4857