

	A	B	C	D	E	F	G	SERIES 2 L DRILL	
INCH	.327	1.109	.900	.350	2.250	3.106	6.188	MAXIMUM RECOMMENDED DRILL DIAMETER	.250 INCH
MM	8.30	28.16	22.86	8.89	57.15	78.89	157.1		6.35 mm

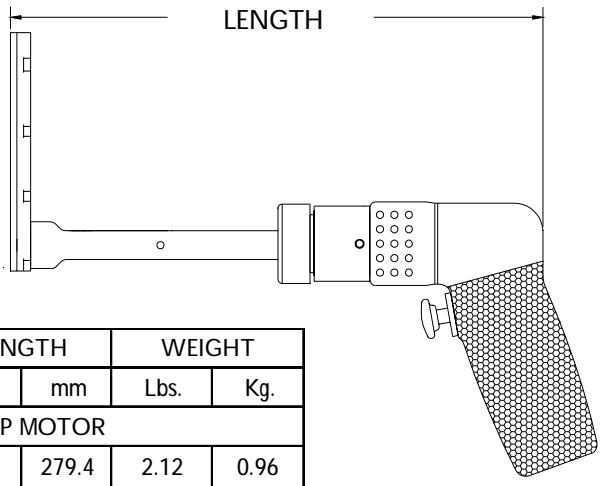

13821 ATTACHMENT ONLY EXTENDED

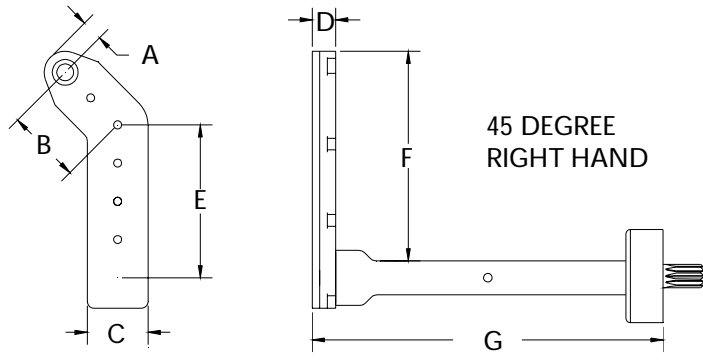

TOOL ORDER NUMBER	R.P.M.	LENGTH		WEIGHT	
		Inch	mm	Lbs.	Kg.
D SERIES .30 HP MOTOR					
16356	250	11.0	279.4	2.12	0.96
14120	500	11.0	279.4	2.12	0.96
14121	750	11.0	279.4	2.12	0.96
14122	1000	11.0	279.4	2.12	0.96
14123	1500	11.0	279.4	2.12	0.96
14124	2800	10.1	256.5	1.84	0.83
D2 SERIES .60 HP MOTOR					
16357	250	12.95	328.9	3.69	1.67
14125	450	12.35	313.6	2.99	1.35
14126	1000	12.35	313.6	2.99	1.35
14127	2000	11.10	281.9	2.74	1.24
14128	2700	11.10	281.9	2.74	1.24
14129	3500	11.10	281.9	2.74	1.24
RD2 .40 HP REVERSIBLE MOTOR					
16358	250	12.95	328.9	3.69	1.67
14130	450	12.35	313.6	3.24	1.46
14131	1000	12.35	313.6	3.24	1.46
14132	2000	11.10	281.9	2.99	1.35
14133	2700	11.10	281.9	2.99	1.35
14134	3500	11.10	281.9	2.99	1.35

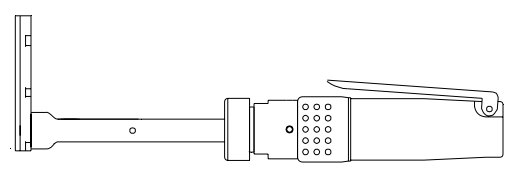

Add an S after the tool order number for the straight handle option.

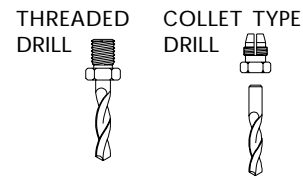

INTERNAL THREAD	
ADD TO TOOL No.	
1/4-28	A
10-32	C
9/32-40	E
5/16-24	F
COLLET	D

PHONE: 1 775 883 1072 FAX: 1 775 883 4857