

	A	B	C	D	E	F	G	SERIES 2 L DRILL	
INCH	.327	3.359	.900	.350	4.127	3.427	6.188	MAXIMUM RECOMMENDED DRILL DIAMETER	.250 INCH
MM	8.30	85.31	22.86	8.89	104.8	87.04	157.1		6.35 mm

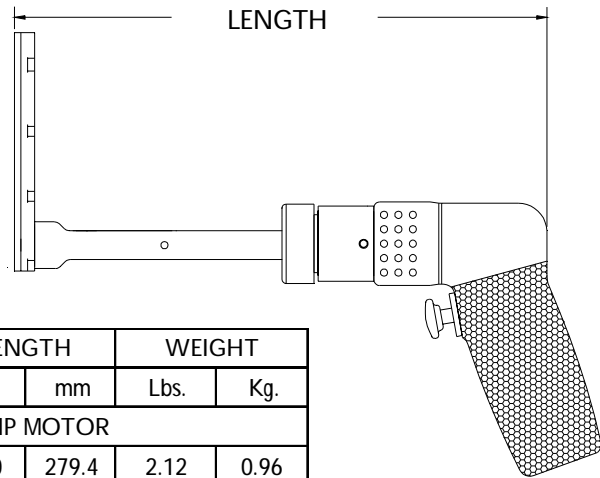

13819 ATTACHMENT ONLY EXTENDED

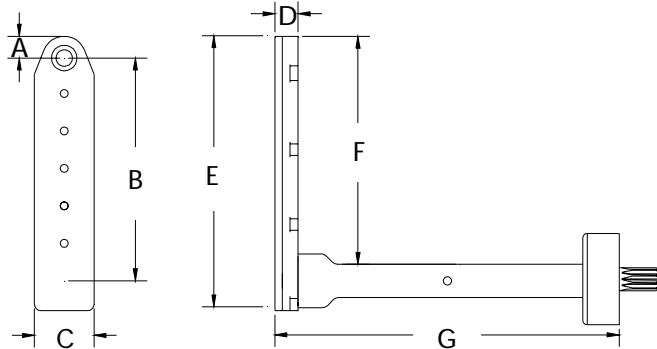

TOOL ORDER NUMBER	R.P.M.	LENGTH		WEIGHT	
		Inch	mm	Lbs.	Kg.
D SERIES .30 HP MOTOR					
16350	250	11.0	279.4	2.12	0.96
14090	500	11.0	279.4	2.12	0.96
14091	750	11.0	279.4	2.12	0.96
14092	1000	11.0	279.4	2.12	0.96
14093	1500	11.0	279.4	2.12	0.96
14094	2800	10.1	256.5	1.84	0.83
D2 SERIES .60 HP MOTOR					
16351	250	12.95	328.9	3.69	1.67
14095	450	12.35	313.6	2.99	1.35
14096	1000	12.35	313.6	2.99	1.35
14097	2000	11.10	281.9	2.74	1.24
14098	2700	11.10	281.9	2.74	1.24
14099	3500	11.10	281.9	2.74	1.24
RD2 .40 HP REVERSIBLE MOTOR					
15994	250	12.95	328.9	3.69	1.67
14100	450	12.35	313.6	3.24	1.46
14101	1000	12.35	313.6	3.24	1.46
14102	2000	11.10	281.9	2.99	1.35
14103	2700	11.10	281.9	2.99	1.35
14104	3500	11.10	281.9	2.99	1.35

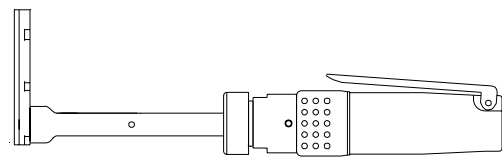

Add an S after the tool order number for the straight handle option.

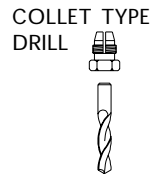

INTERNAL THREAD	
ADD TO TOOL No.	
1/4-28	A
10-32	C
9/32-40	E
5/16-24	F
COLLET	D

PHONE: 1 775 883 1072 FAX: 1 775 883 4857