

	A	B	C	D	E	F	G	SERIES 2 L DRILL	
INCH	.327	1.671	.900	.350	2.440	1.739	6.188	MAXIMUM RECOMMENDED DRILL DIAMETER	.250 INCH
MM	8.30	42.44	22.86	8.89	61.97	44.17	157.1		6.35 mm

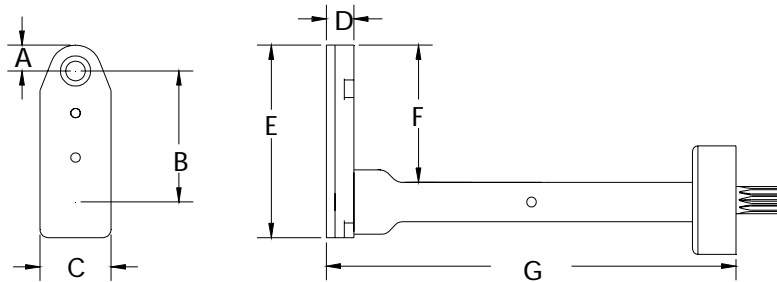

13815 ATTACHMENT ONLY EXTENDED



THIS ATTACHMENT REQUIRES A REVERSE RUNNING (K)  
OR REVERSIBLE MOTOR.

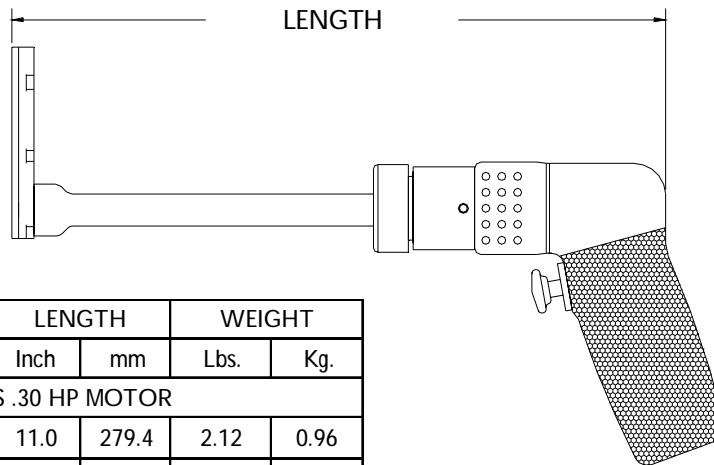

TOOL ORDER NUMBER	R.P.M.	LENGTH		WEIGHT	
		Inch	mm	Lbs.	Kg.
DK SERIES .30 HP MOTOR					
16338	250	11.0	279.4	2.12	0.96
14023	500	11.0	279.4	2.12	0.96
14024	750	11.0	279.4	2.12	0.96
14025	1000	11.0	279.4	2.12	0.96
14028	1500	11.0	279.4	2.12	0.96
14029	2800	10.1	256.5	1.84	0.83
D2K SERIES .60 HP MOTOR					
16339	250	12.95	328.9	3.69	1.67
14034	450	12.35	313.6	2.99	1.35
14035	1000	12.35	313.6	2.99	1.35
14036	2000	11.10	281.9	2.74	1.24
14037	2700	11.10	281.9	2.74	1.24
14038	3500	11.10	281.9	2.74	1.24
RD2 .40 HP REVERSIBLE MOTOR					
16340	250	12.95	328.9	3.69	1.67
14039	450	12.35	313.6	3.24	1.46
14040	1000	12.35	313.6	3.24	1.46
14041	2000	11.10	281.9	2.99	1.35
14042	2700	11.10	281.9	2.99	1.35
14043	3500	11.10	281.9	2.99	1.35

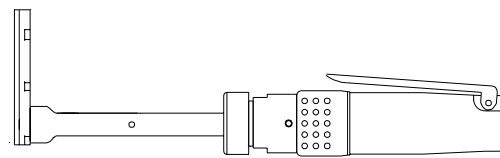

Add an S after the tool order number  
for the straight handle option.

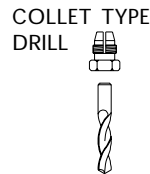

INTERNAL THREAD	
ADD TO TOOL No.	
1/4-28	A
10-32	C
9/32-40	E
5/16-24	F
COLLET	D

PHONE: 1 775 883 1072 FAX: 1 775 883 4857