

	A	B	C	D	E	F	G	SERIES 1 L DRILL	
INCH	.327	1.109	.900	.250	2.250	3.106	1.858	MAXIMUM RECOMMENDED DRILL DIAMETER	.1875 INCH
MM	8.30	28.16	22.86	6.35	57.15	78.89	47.19		4.76 mm

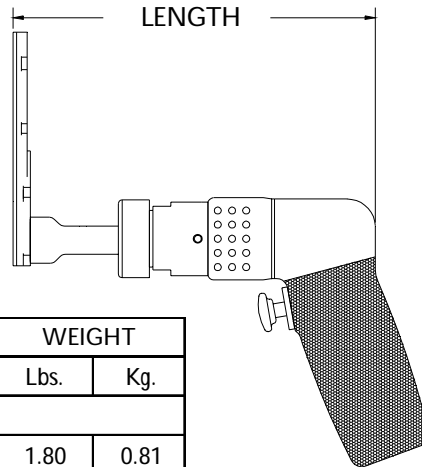

13812 ATTACHMENT ONLY SHORT

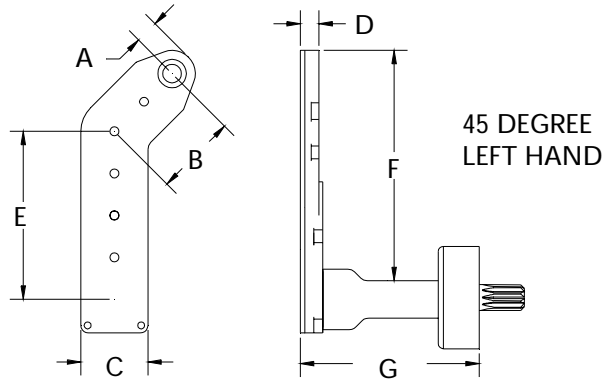

TOOL ORDER NUMBER	R.P.M.	LENGTH		WEIGHT	
		Inch	mm	Lbs.	Kg.
D SERIES .30 HP MOTOR					
16329	250	6.90	175.2	1.80	0.81
13977	500	6.90	175.2	1.80	0.81
13978	750	6.90	175.2	1.80	0.81
13979	1000	6.90	175.2	1.80	0.81
13980	1500	6.90	175.2	1.80	0.81
13981	2800	6.00	152.4	1.52	0.68
D2 SERIES .60 HP MOTOR					
16330	250	8.85	224.7	3.37	1.53
13982	450	8.25	209.5	2.67	1.21
13983	1000	8.25	209.5	2.67	1.21
13984	2000	7.00	177.8	2.42	1.09
13985	2700	7.00	177.8	2.42	1.09
13986	3500	7.00	177.8	2.42	1.09
RD2 .40 HP REVERSIBLE MOTOR					
16331	250	8.85	224.7	3.37	1.53
13987	450	8.25	209.5	2.92	1.32
13988	1000	8.25	209.5	2.92	1.32
13989	2000	7.00	177.8	2.67	1.21
13990	2700	7.00	177.8	2.67	1.21
13991	3500	7.00	177.8	2.67	1.21

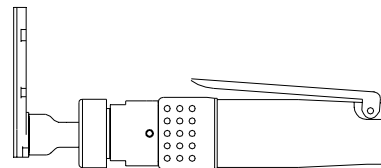

Add an S after the tool order number for the straight handle option.

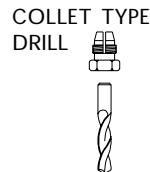

INTERNAL THREAD	
ADD TO TOOL No.	
1/4-28	A
10-32	C
9/32-40	E
5/16-24	F
COLLET	D

PHONE: 1 775 883 1072 FAX: 1 775 883 4857