

	A	B	C	D	E	F	G	SERIES 1 L DRILL	
INCH	.327	1.109	.900	.250	2.250	3.106	6.188	MAXIMUM RECOMMENDED DRILL DIAMETER	.1875 INCH
MM	8.30	28.16	22.86	6.35	57.15	78.89	157.1		4.76 mm

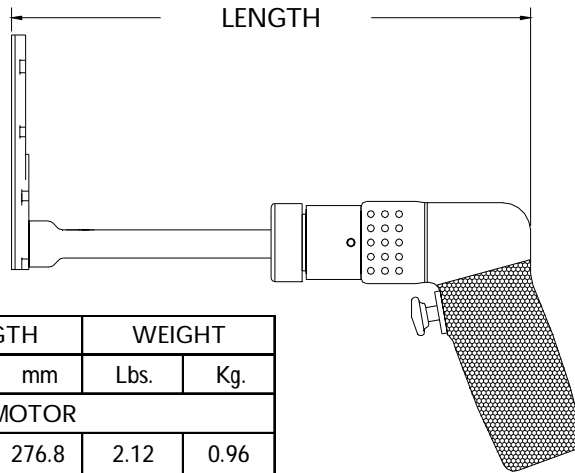

13809 ATTACHMENT ONLY EXTENDED

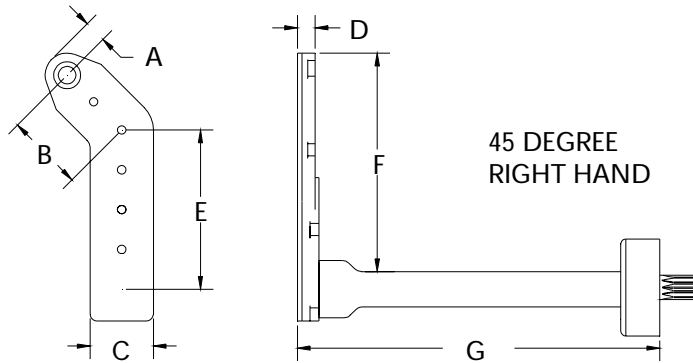

TOOL ORDER NUMBER	R.P.M.	LENGTH		WEIGHT	
		Inch	mm	Lbs.	Kg.
D SERIES .30 HP MOTOR					
16320	250	10.9	276.8	2.12	0.96
13932	500	10.9	276.8	2.12	0.96
13933	750	10.9	276.8	2.12	0.96
13934	1000	10.9	276.8	2.12	0.96
13935	1500	10.9	276.8	2.12	0.96
13936	2800	10.0	254.0	1.84	0.83
D2 SERIES .60 HP MOTOR					
16321	250	12.85	326.3	3.69	1.67
13937	450	12.25	311.1	2.99	1.35
13938	1000	12.25	311.1	2.99	1.35
13939	2000	11.00	279.4	2.74	1.24
13940	2700	11.00	279.4	2.74	1.24
13941	3500	11.00	279.4	2.74	1.24
RD2 .40 HP REVERSIBLE MOTOR					
16322	250	12.85	326.3	3.69	1.67
13942	450	12.25	311.1	3.24	1.46
13943	1000	12.25	311.1	3.24	1.46
13944	2000	11.00	279.4	2.99	1.35
13945	2700	11.00	279.4	2.99	1.35
13946	3500	11.00	279.4	2.99	1.35

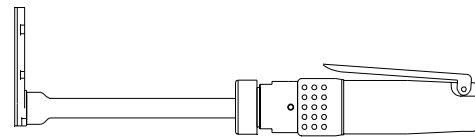

Add an S after the tool order number for the straight handle option.

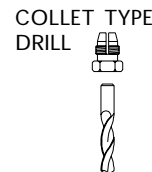

INTERNAL THREAD	
ADD TO TOOL No.	
1/4-28	A
10-32	C
9/32-40	E
5/16-24	F
COLLET	D