

	A	B	C	D	E	F	G	SERIES 1 L DRILL	
INCH	.327	2.234	.900	.250	3.00	2.302	6.188	MAXIMUM RECOMMENDED DRILL DIAMETER	.1875 INCH
MM	8.30	56.74	22.86	6.35	76.20	58.47	157.1		4.76 mm

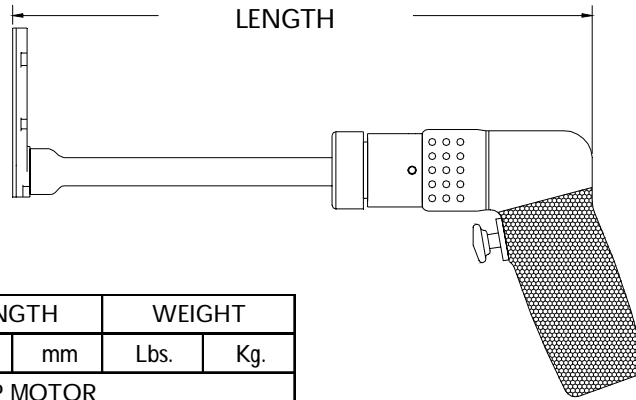

13805 ATTACHMENT ONLY EXTENDED

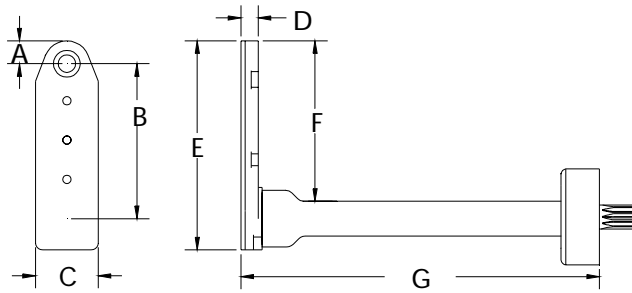

TOOL ORDER NUMBER	R.P.M.	LENGTH		WEIGHT	
		Inch	mm	Lbs.	Kg.
D SERIES .30 HP MOTOR					
16308	250	10.9	276.8	2.12	0.96
13870	500	10.9	276.8	2.12	0.96
13871	750	10.9	276.8	2.12	0.96
13872	1000	10.9	276.8	2.12	0.96
13873	1500	10.9	276.8	2.12	0.96
13874	2800	10.0	254.0	1.84	0.83
D2 SERIES .60 HP MOTOR					
16309	250	12.85	326.3	3.69	1.67
13875	450	12.25	311.1	2.99	1.35
13876	1000	12.25	311.1	2.99	1.35
13878	2000	11.00	279.4	2.74	1.24
13879	2700	11.00	279.4	2.74	1.24
13880	3500	11.00	279.4	2.74	1.24
RD2 .40 HP REVERSIBLE MOTOR					
16310	250	12.85	326.3	3.69	1.67
13881	450	12.25	311.1	3.24	1.46
13882	1000	12.25	311.1	3.24	1.46
13883	2000	11.00	279.4	2.99	1.35
13884	2700	11.00	279.4	2.99	1.35
13885	3500	11.00	279.4	2.99	1.35

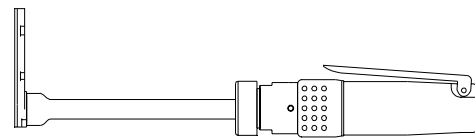

Add an S after the tool order number for the straight handle option.

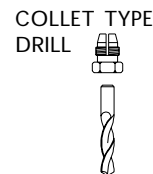

INTERNAL THREAD	
ADD TO TOOL No.	
1/4-28	A
10-32	C
9/32-40	E
5/16-24	F
COLLET	D