

	A	B	C	D	E	F	G	SERIES 1 L DRILL	
INCH	.327	1.671	.900	.250	2.440	1.739	6.188	MAXIMUM RECOMMENDED DRILL DIAMETER	.1875 INCH
MM	8.30	42.44	22.86	6.35	61.97	44.17	157.1		4.76 mm

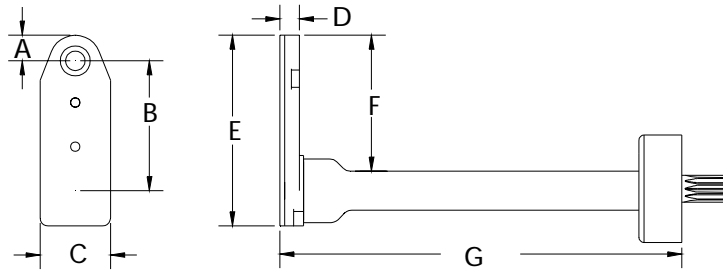

13803 ATTACHMENT ONLY EXTENDED



THIS ATTACHMENT REQUIRES A REVERSE RUNNING (K) OR REVERSIBLE MOTOR.

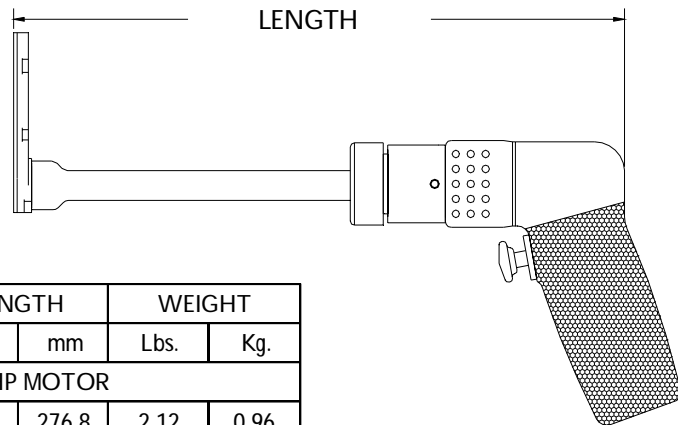

TOOL ORDER NUMBER	R.P.M.	LENGTH		WEIGHT	
		Inch	mm	Lbs.	Kg.
DK SERIES .30 HP MOTOR					
16302	250	10.9	276.8	2.12	0.96
13840	500	10.9	276.8	2.12	0.96
13841	750	10.9	276.8	2.12	0.96
13842	1000	10.9	276.8	2.12	0.96
13843	1500	10.9	276.8	2.12	0.96
13844	2800	10.0	254.0	1.84	0.83
D2K SERIES .60 HP MOTOR					
16303	250	12.85	326.3	3.69	1.67
13845	450	12.25	311.1	2.99	1.35
13846	1000	12.25	311.1	2.99	1.35
13847	2000	11.00	279.4	2.74	1.24
13848	2700	11.00	279.4	2.74	1.24
13849	3500	11.00	279.4	2.74	1.24
RD2 .40 HP REVERSIBLE MOTOR					
16304	250	12.85	326.3	3.69	1.67
13850	450	12.25	311.1	3.24	1.46
13851	1000	12.25	311.1	3.24	1.46
13852	2000	11.00	279.4	2.99	1.35
13853	2700	11.00	279.4	2.99	1.35
13854	3500	11.00	279.4	2.99	1.35

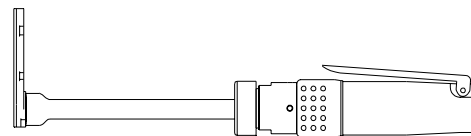

Add an S after the tool order number for the straight handle option.

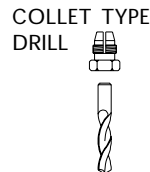

INTERNAL THREAD	
ADD TO TOOL No.	
1/4-28	A
10-32	C
9/32-40	E
5/16-24	F
COLLET	D