

	A	B	C	D	E	F	G	H	SERIES 1 17 DEGREE DRILL	
INCH	.250	2.23	3.1	.90	1.02	.327	1.68	1.10	MAXIMUM RECOMMENDED DRILL DIAMETER	
MM	6.35	56.06	78.7	22.8	25.9	6.01	42.6	27.9	.1875 INCH 4.76 mm	

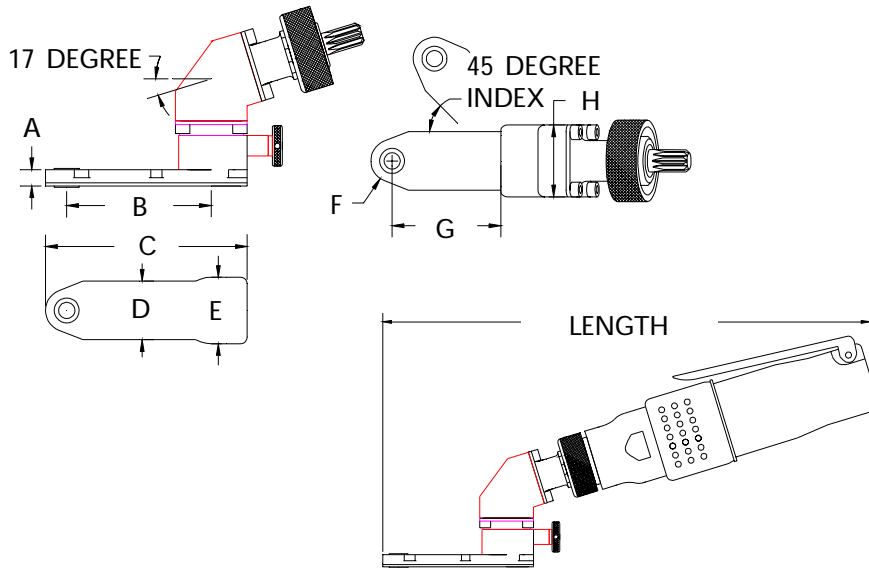

SERIES 1 INDEXABLE 17 DEGREE DRILLS



16230 ATTACHMENT ONLY PART OF THE JIFFY MODULAR DRILL SYSTEM

The high nickel alloy used in our drill attachment gears make this unit SUPERIOR in drilling performance.

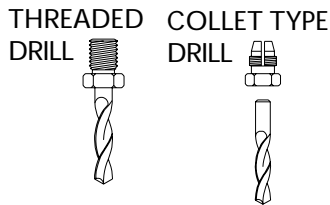

INTERNAL THREAD	
ADD TO TOOL No.	
1/4-28	A
10-32	C
9/32-40	E
5/16-24	F
COLLET	D

TOOL ORDER NUMBER	R.P.M.	LENGTH		WEIGHT	
		Inch	mm	Lbs.	Kg.
SD SERIES .30 HP MOTOR					
16424	250	10.5	266	1.8	.81
16425	500	10.5	266	1.8	.81
16426	750	10.5	266	1.8	.81
16427	1000	10.5	266	1.8	.81
16428	1500	10.5	266	1.8	.81
16429	2800	9.6	243	1.6	.72
SD2 SERIES .60 HP MOTOR					
16430	250	11.8	299	3.0	1.3
16431	450	10.9	276	2.6	1.1
16432	1000	10.9	276	2.6	1.1
16433	2000	9.9	251	2.2	1.0
16434	2700	9.9	251	2.2	1.0
16435	3500	9.9	251	2.2	1.0
SRD2 REVERSIBLE .40 HP MOTOR					
16436	250	11.8	299	3.0	1.3
16437	450	10.9	276	2.6	1.1
16438	1000	10.9	276	2.6	1.1
16439	2000	9.9	251	2.2	1.0
16440	2700	9.9	251	2.2	1.0