

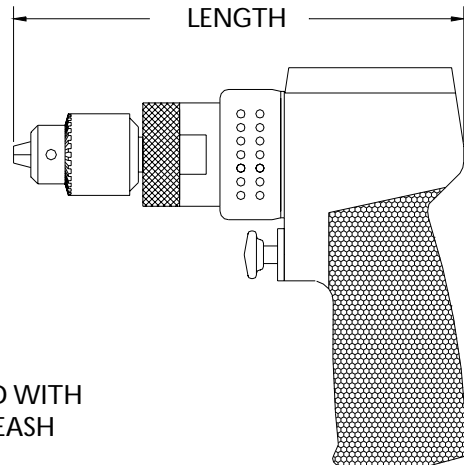

## RD2 DRILL MOTORS .40 HP WITH CHUCKS 1A AND 2A JACOBS TAPER



ALL DRILLS SUPPLIED WITH  
CHUCK KEY AND LEASH

RPM	TOOL NUMBER		TORQUE		WEIGHT NO CHUCK		LENGTH APPROX	
	0-3/8 CHUCK	5/64-1/2 CHUCK						
	0-10mm	2-13mm	IN LBS	Nm	LBS.	KG.	INCH	MM
150		15115	420	47.5	3.23	1.46	9 3/4	248
250	15110	15116	270	30.5	3.23	1.46	9 3/4	248
450	15111	15117	190	21.5	2.87	1.3	8 7/8	225
1000	15112	15118	85	9.6	2.87	1.3	8 7/8	225
2000	15113		55	6.2	2.44	1.1	6 3/4	171
2700	15114		47	5.3	2.44	1.1	6 3/4	171
3500			34	3.8	2.44	1.1	6 3/4	171

WEIGHT	0-3/8 CHUCK 2A TAPER	0-1/2 CHUCK 2A TAPER
	0-10MM CHUCK 2A TAPER	0-13MM CHUCK 2A TAPER
LBS.	.76	1.47
KG.	.34	.67

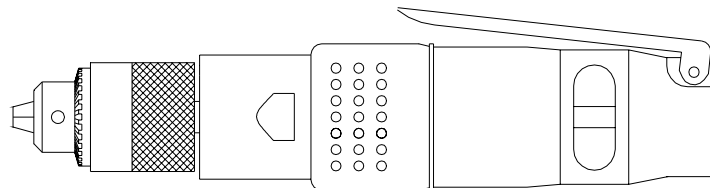

ADD AN S AFTER THE TOOL ORDER NUMBER  
FOR THE STRAIGHT HANDLE OPTION