

D2 DRILL MOTORS .60 HP WITH CHUCKS

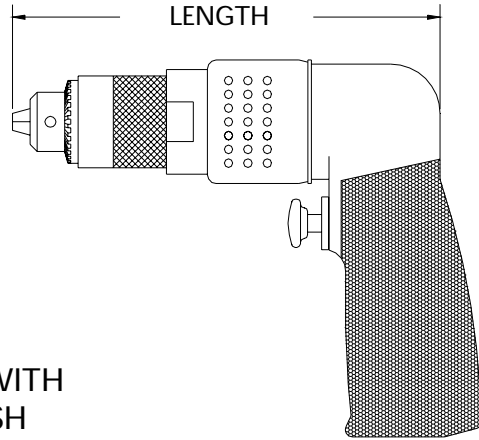

3/8 - 24 THREAD



ALL DRILLS SUPPLIED WITH
CHUCK KEY AND LEASH

RPM	TOOL NUMBER			TORQUE		WEIGHT NO CHUCK		LENGTH APPROX	
	0-1/4 CHUCK	0-3/8 CHUCK	5/64-1/2 CHUCK	IN LBS	Nm	LBS.	KG.	INCH	MM
	0-6.5mm	0-10mm	2-13mm						
150			15100	500	56.5	2.81	1.3	9 3/4	248
250	15088	15095	15101	300	33.9	2.81	1.3	9 3/4	248
450	15089	15096	15102	240	27.1	2.45	1.1	8 7/8	225
1000	15090	15097	15103	105	11.9	2.45	1.1	8 7/8	225
2000	15091	15098	15104	66	7.46	2.02	.92	6 3/4	171
2700	15092	15099		55	6.2	2.02	.92	6 3/4	171
3500	15093	15190		40	4.5	2.02	.92	6 3/4	171
15000	15094			10	1.1	2.02	.92	6 3/4	171

WEIGHT	0-1/4 CHUCK	0-3/8 CHUCK	5/64-1/2 CHUCK
	0-6.5MM CHUCK	0-10MM CHUCK	2-13MM CHUCK
LBS.	.38	.76	.94
KG.	.17	.34	.43

DRILLS WITH STRAIGHT HANDLES

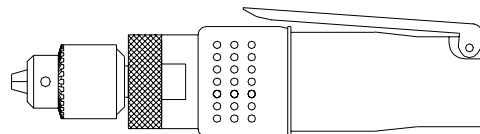

TO ORDER DRILLS WITH STRAIGHT HANDLES
ADD S TO TOOL ORDER NUMBER

ADD M TO TOOL ORDER NUMBER FOR 7BA
HEAVY DUTY CHUCK 0-1/4" ONLY

PHONE: 1 775 883 1072 FAX: 1 775 883 4857